

IAP-270 Series Outdoor Access Point

Installation Guide

The Aruba IAP-274 and IAP-275 are environmentally hardened, outdoor rated, dual-radio IEEE 802.11ac wireless access points. These access points use MIMO (Multiple-in, Multiple-out) technology and other high-throughput mode techniques to deliver high-performance, 802.11ac 2.4 GHz and 5 GHz functionality while simultaneously supporting existing 802.11a/b/g/n wireless services.

IAP-270 Series Operations

- Wireless transceiver
- Wireless access point (IEEE 802.11 a/b/g/n/ac)
- Wireless air monitor (IEEE 802.11 a/b/g/n/ac)
- Protocol-independent networking functionality
- Compatibility with IEEE 802.3at PoE



The IAP-270 Series requires Aruba Instant 4.1 or later.

Guide Overview

- ["IAP-270 Series Hardware Overview"](#) on page 3 provides a detailed hardware overview of the IAP-274 and IAP-275.
- ["Before You Begin"](#) on page 7 provides key questions to ask and items to consider when deploying an outdoor wireless network.
- ["Installing the AP"](#) on page 8 describes the multi-step process for a successful installation and deployment of the IAP-274 and IAP-275.
- ["Safety and Regulatory Compliance"](#) on page 14 provides an overview of safety and regulatory compliance information.

Package Contents

- IAP-274 or IAP-275 Access Point
- Cable Glands x2
- Copper Lug x1
- M4x6 Screw x1
- USB Console Cable
- Aruba Instant Quick Start Guide
- Installation Guide (this document)



The weatherproof caps for Ethernet, Console, and power interfaces are connected to the AP, not loose in the package.



Mounting kits for use with the IAP-270 Series access points are sold separately. Contact your Aruba sales representative for details.



Inform your supplier if there are any incorrect, missing, or damaged parts. If possible, retain the carton, including the original packing materials. Use these materials to repack and return the unit to the supplier if needed.

IAP-270 Series Hardware Overview

Figure 1 IAP-274 Front View (Aesthetic Cover Removed)

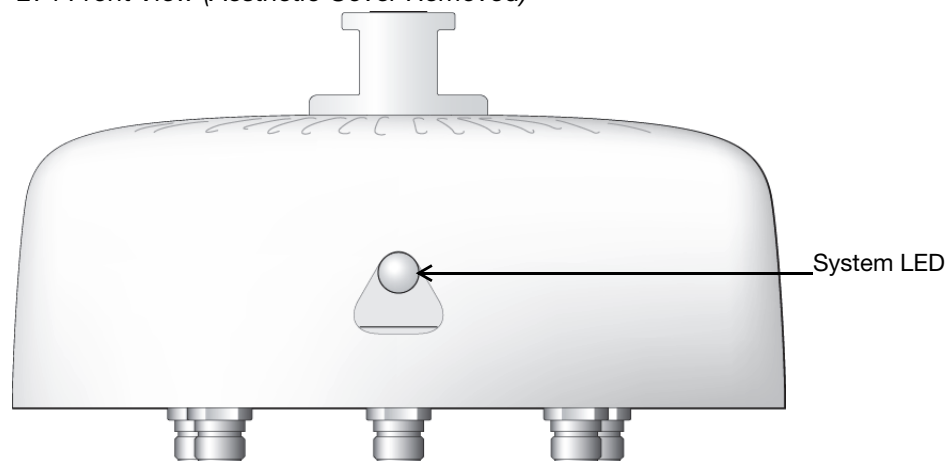

The antenna connectors of IAP-274 are covered by an aesthetic cover in the package. The aesthetic cover can be removed when necessary.

Figure 2 IAP-275 Front View

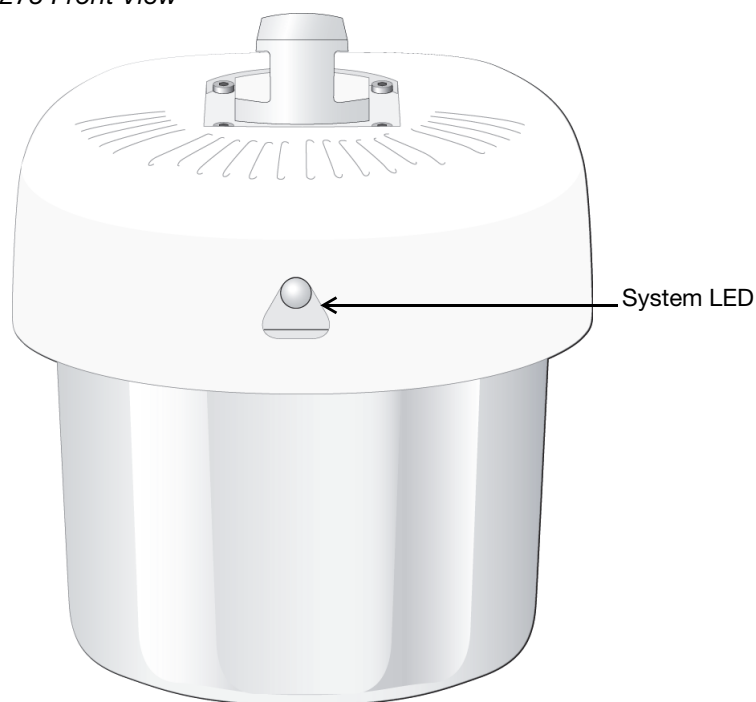

LED

The IAP-270 Series is equipped with one LED that indicates the system status of the AP.

Table 1 IAP-270 Series LED Meanings during Boot Up

LED	Color/State	Meaning
System LED	Off	No power to AP
	Red	Initial power-up
	Green - Flashing	AP booting
	Green - Steady	AP ready and 1000Mbps Ethernet link established. The LED turns off after 1200 seconds
	Green - Yellow, 6 seconds period	AP ready and 10/100Mbps Ethernet link established. The LED turns off after 1200 seconds

Table 2 IAP-270 Series LED Meanings during Operation

LED	Color/State	Meaning
System LED	Solid Red	General fault
	One blink off every 3 seconds	Radio 0 fault (5 GHz)
	Two quick blink off 0.5 seconds apart cycled every 3 seconds	Radio 1 fault (2.4GHz)

Figure 3 IAP-274 Rear View

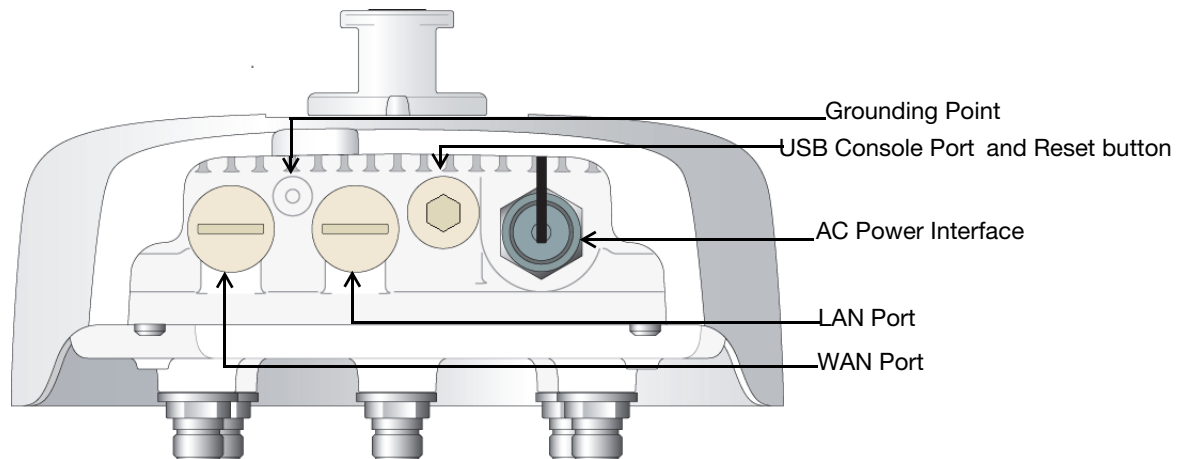
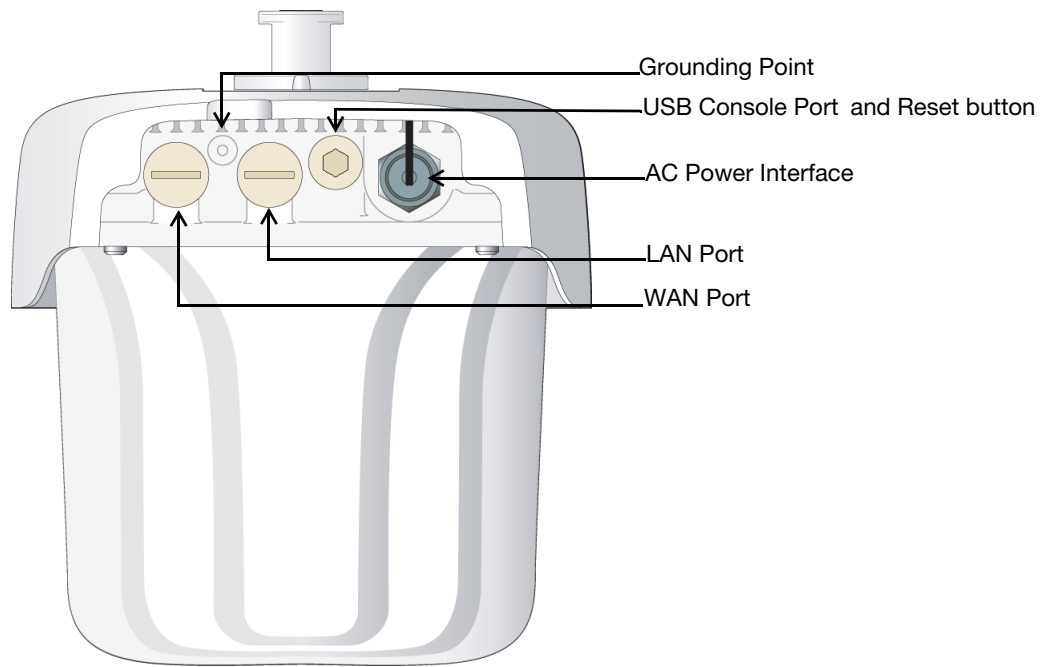

Figure 4 IAP-275 Rear View



USB Console Port

The USB Micro-B console port allows you to connect the AP to a terminal or a laptop for direct local management. Use the included USB console cable to connect the AP. You can download the necessary driver for USB-UART adapter from support.arubanetworks.com under the **Tools & Resources** tab.

Use the following setting to access the terminal:

Table 3 Console Settings

Baud Rate	Data Bits	Parity	Stop Bits	Flow Control
9600	8	None	1	None

Ethernet Ports

IAP-270 Series is equipped with two 10/100/1000Base-T (RJ-45) Gigabit Ethernet ports (WAN and LAN port) for wired network connectivity. The WAN port supports 802.3at Power over Ethernet (PoE), accepting 48 VDC (nominal) as a standard defined Powered Device (PD) from a Power Sourcing Equipment (PSE) such as a PoE midspan injector.

These ports have RJ-45 female connectors with the pin-outs shown in [Figure 5](#).

Figure 5 Gigabit Ethernet Port Pin-Out

1000Base-T Gigabit Ethernet Port	RJ-45 Female Pin-Out	Signal Name	Function
	1	BI_DA+	Bi-directional pair +A, POE Negative
	2	BI_DA-	Bi-directional pair -A, POE Negative
	3	BI_DB+	Bi-directional pair +B, POE Positive
	4	BI_DC+	Bi-directional pair +C, POE Positive
	5	BI_DC-	Bi-directional pair -C, POE Positive
	6	BI_DB-	Bi-directional pair -B, POE Positive
	7	BI_DD+	Bi-directional pair +D, POE Negative
	8	BI_DD-	Bi-directional pair -D, POE Negative

Reset Button

The reset button can be used to return the AP to factory default settings. To reset the AP:

1. Power off the AP.
2. Press and hold the reset button using a small, narrow object, such as a paperclip.
3. Power-on the AP without releasing the reset button. The system LED will flash within 5 seconds.
4. Release the reset button.

The system LED will flash again within 15 seconds indicating that the reset is completed. The AP will now continue to boot with the factory default settings.

AC Power Interface

The IAP-270 Series is capable of AC power in the range of 100 - 240 VAC. The power cord or power connector kit is sold separately.

Grounding Point

Always remember to protect the AP by installing grounding lines. The ground connection must be complete before connecting power to the AP enclosure.

Figure 6 IAP-274 and IAP-275 Top View

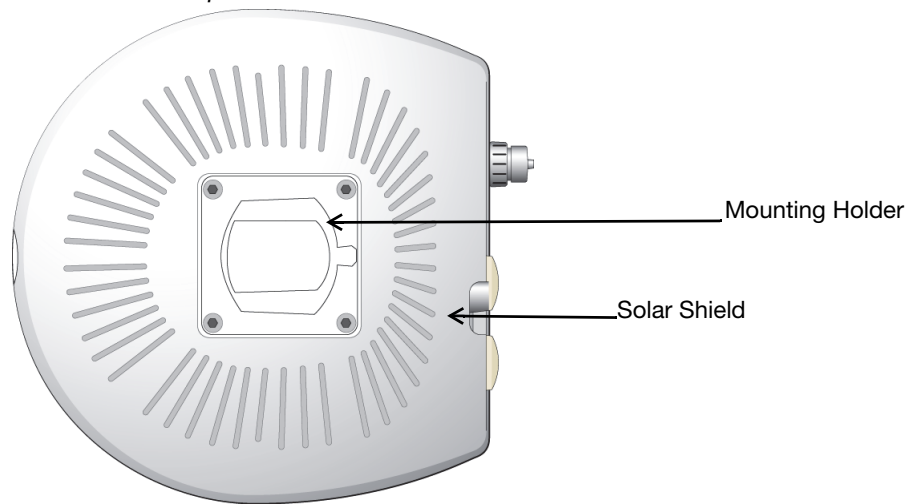

At the top of the IAP-270 Series, the solar shield with the mounting holder is fixed onto the AP before shipping from the factory.

Figure 7 IAP-274 Bottom View

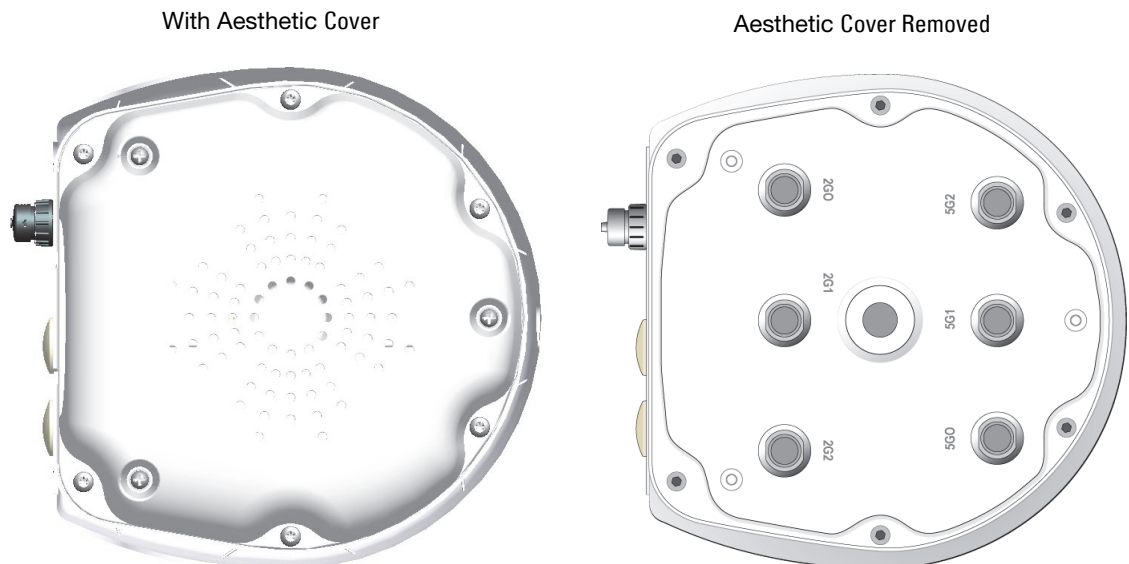
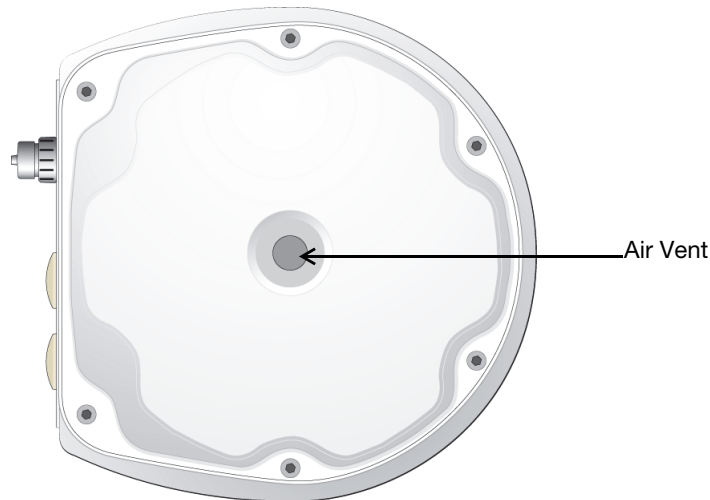

Figure 8 IAP-275 Bottom View



External Antenna Connectors

The IAP-274 is equipped with six N-type female connectors for external antenna. The connectors are labeled 2G0, 2G1, 2G2, 5G0, 5G1 and 5G2, and correspond to 2.4/5GHz radio chains 0,1, and 2.



Please install the external antennas according to the manufacturer's instruction and connect the antennas to the N-type female antenna connectors on the IAP-274 access point.

External antennas for this device must be installed by an Aruba Certified Mobility Professional (ACMP) or other Aruba-certified technician, using manufacturer-approved antennas only.

The Equivalent Isotropically Radiated Power (EIRP) levels for all external antenna devices must not exceed the regulatory limit set by the host country/domain.

Installers are required to record the antenna gain for this device in the system management software.



Les antennes externes pour cet appareil doivent être installées par un professionnel de la mobilité certifié Aruba (ACMP) ou un autre technicien certifié Aruba, en utilisant uniquement des antennes approuvées par le fabricant. Les niveaux équivalents de puissance à rayonnement isotrope (EIRP) pour tous les périphériques d'antenne externe ne doivent pas dépasser la limite réglementaire définie par le pays hôte / domaine. Les installateurs doivent enregistrer le gain d'antenne pour cet appareil dans le logiciel de gestion du système.

Air Vent

The bottom of the IAP-270 Series has an air vent to balance the pressure and humidity inside and outside the AP. It also allows air exchange between the AP and the environment in a controlled way that doesn't allow water to get into the AP.

Before You Begin



FCC Statement: Improper termination of access points installed in the United States (non-US model Regulatory Domain model/s) will be in violation of the FCC grant of equipment authorization. Any such willful or intentional violation may result in a requirement by the FCC for immediate termination of operation and may be subject to forfeiture (47 CFR 1.80).

EU Statement:

Lower power radio LAN product operating in 2.4 GHz and 5 GHz bands. Please refer to the *Aruba Instant User Guide* for details on restrictions.



Produit réseau local radio basse puissance opérant dans la bande fréquence 2.4 GHz et 5 GHz. Merci de vous référer au *Aruba Instant User Guide* pour les détails des restrictions.

Low Power FunkLAN Produkt, das im 2.4 GHz und im 5 GHz Band arbeitet. Weitere Informationen bezüglich Einschränkungen finden Sie im *Aruba Instant User Guide*.

Apparati Radio LAN a bassa Potenza, operanti a 2.4 GHz e 5 GHz. Fare riferimento alla *Aruba Instant User Guide* per avere informazioni dettagliate sulle restrizioni.



Aruba Networks, Inc. in compliance with governmental requirements, has designed the IAP-270 Series such that only authorized network administrators can change configuration settings. For more information about AP configuration, refer to the *Aruba Instant Quick Start Guide* and *Aruba Instant User Guide*.



Access points are radio transmission devices and as such are subject to governmental regulation. Network administrators responsible for the configuration and operation of access points must comply with local broadcast regulations. Specifically, access points must use channel assignments appropriate to the location in which the access point will be used.

Identifying Specific Installation Locations

You can mount the IAP-270 Series access point on a wall or pole. Use the AP placement map generated by Aruba's RF Plan software application to determine the proper installation location(s). Each location should be as close as possible to the center of the intended coverage area and should be free from obstructions or obvious sources of interference. These RF absorbers/reflectors/interference sources will impact RF propagation and should have been accounted for during the planning phase and adjusted for in RF plan.

Identifying Known RF Absorbers/Reflectors/Interference Sources

Identifying known RF absorbers, reflectors, and interference sources while in the field during the installation phase is critical. Make sure that these sources are taken into consideration when you attach an AP to its fixed location. Examples of sources that degrade RF performance include:

- Cement and brick
- Objects that contain water
- Metal
- Microwave ovens
- Wireless phones and headsets

Installing the AP



Service to all Aruba products should be performed by trained service personnel only.

Using the Mounting Kits

The IAP-270 Series can be installed on a wall or attached to a pole by using mounting kits:

Table 4 Applicable Mounting Kits for IAP-270 Series

Part Number	Description
AP-270-MNT-V1	Long mounting kit for wall and vertical pole mounting, 300 mm from vertical mounting asset.
AP-270-MNT-V2	Short mounting kit for wall and vertical pole mounting, 75 mm from vertical mounting asset.
AP-270-MNT-H1	Mounting kit for hanging from inclined or horizontal structure.



The IAP-270 Series access point does not ship with any mounting kits. These mounting kits are available as accessories and must be ordered separately.



For installation instructions on AP-270-MNT-V1, AP-270-MNT-V2 and AP-270-MNT-H1, please refer to the *AP-270-MNT-V1 Installation Guide*, *AP-270-MNT-V2 Installation Guide* and *AP-270-MNT-H1 Installation Guide* respectively.

Grounding the AP

The grounding must be completed before powering up the AP. The grounding wire should be #8 AWG.

1. Peel the cover of one end of the grounding wire and place the bare grounding wire into the included copper lug, and press firmly with the crimping pliers.
2. Fasten the copper lug to the grounding hole on the AP with the included M4 x6 screw as shown in [Figure 9](#).

Figure 9 Grounding the AP

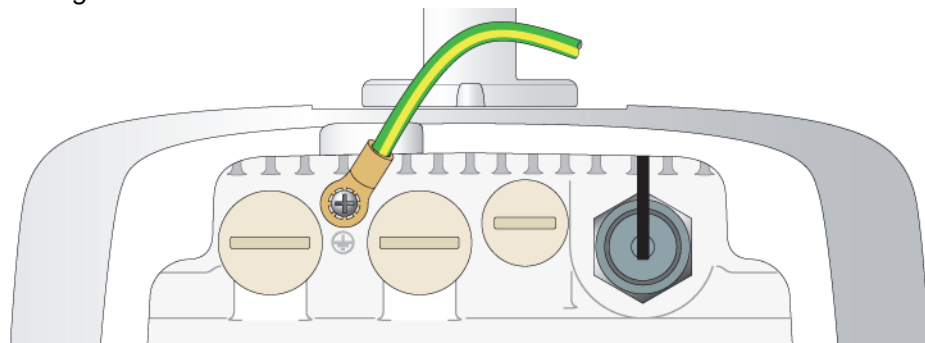

Connecting the Ethernet Cable

To connect the Ethernet cable to the AP, perform the following steps using the cable glands that ships with your AP.



Failure to use the included Ethernet cable glands can lead to connectivity and POE issues.



The cable is not included and must be purchased separately. Purchase a suitable UV-resistant, outdoor rated, CAT 5E or better RJ45 cable for use with the AP.

Figure 10 *Installing a Cable Gland*

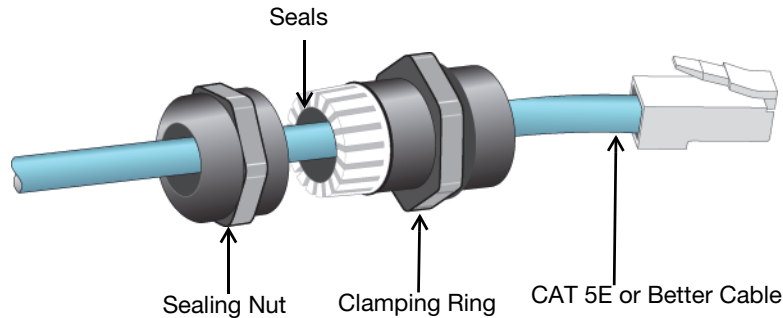

1. Slide the sealing nut over the cable (without the RJ45 connector attached to the end).
2. Slide the clamping ring over the cable.
3. Using a crimping tool, attach the shielded RJ45 connector to the end of the cable.
4. Remove the weatherproof cap on the Ethernet port.
5. Insert the RJ45 connector to the Ethernet port.
6. Screw the clamping ring onto the Ethernet port.
7. Screw the sealing nut onto the clamping ring.



The seals inside the clamping ring by factory default is applicable for cables with 5-8.5 mm diameter. In the cable gland kit, another seals is provided for use with the cables with 7-10 mm diameter.

Connecting the Power Cable



Installation and service of Aruba products should be performed by Professional Installers in a manner that is consistent with the electrical code in force in the jurisdiction of deployment. In many countries this will require a licensed electrician to perform this operation. In Japan, this is a Certified Electrician by Ministry of Economy, Trade, and Industry.



The IAP-270 Series does not ship with any power cables. These are available as accessories and should be ordered separately.

The IAP-270 Series product offering offers two ways to connect the unit to AC power. Two power cord variants are offered and a connector kit that allows the customer to assemble their own cable if the standard offering does not meet deployment needs.

The applicable SKUs for these options are:

Table 5 *SKUs for Powering Options*

Part Number	Description
PC-OD-AC-P-NA	Weatherproof AC power cable(5m), North America version
PC-OD-AC-P-INT	Weatherproof AC power cable(5m), International (EU) version

Table 5 SKUs for Powering Options

Part Number	Description
CKIT-OD-AC-P	Weatherproof connector kit for AC power interface

The difference between the NA and INTL part variants is the color coding of the conductors.

- The North American cable uses Black (Hot), White (Neutral), and Green (Ground).
- The INTL part follows the international schema of Brown (Hot), Blue (Neutral) and Yellow/Green (Ground)

Please only use included or Aruba specified cables, power cords, AC power supplies and batteries. The power cord should not be used with other electric equipment than what is specified by Aruba



CAUTION

接続ケーブル、電源コード、ACアダプタ、バッテリーなどの部品は、必ず添付品または指定品をご使用ください。また、電源ケーブルは弊社が指定する製品以外の電気機器には使用できないためご注意ください。

Best Practice for Outdoor Connection to AC Mains

In all circumstances and with any outdoor infrastructure the recommended practice is to connect to AC mains in an order grade weather protected junction box. This needs to be implemented by a qualified resource in a manner that is consistent with the electrical code in force in the jurisdiction of deployment. In many countries this will require a licensed electrician to perform this operation.

In Japan, this would be a Certified Electrician by Ministry of Economy, Trade and Industry.

The use of plugs with infrastructure equipment is suitable only for temporary installs where nuisance tripping of GFI plugs is considered tolerable. Should it be desired to attach a plug to the cable assemblies then the installer is expected to follow all directions provided with the plug end in a fashion consistent with local electrical code.

Use of the CKIT-OD-AC-P

Assembly instructions for this part are shipped with the part. All instructions must be followed to ensure proper assembly of the connector onto the cable.

The required specifications for third party cable used with the CKIT solution are as follows:

- AC power cable specifications (when using AC connector kit and custom cable): minimum voltage/current rating 250V/1A, diameter 6-12mm, rated for outdoor use and UV exposure

AC Power Cable Connector PIN OUT

Figure 11 AC power cable connector

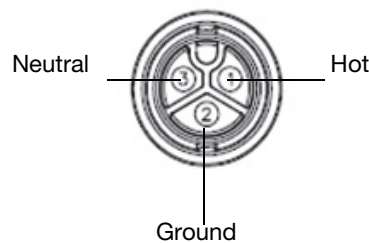

Connecting the Power Cable to the IAP-275

1. Remove the weatherproof cap on the power interface.

2. Insert the power cable connector into the power interface and hand-fasten the locknut.

Verifying Post-Installation Connectivity

The integrated LEDs on the AP can be used to verify that the AP is receiving power and initializing successfully (see [Table 1](#) and [Table 2](#)). Refer to the *Aruba Instant Quick Start Guide* for further details on verifying post-installation network connectivity.

Product Specifications

Mechanical:

- Device Dimensions (HxWxD)
 - IAP-274 (without aesthetic cover): 5.5 inches x 9 inches x 9.4 inches (14cm x 23cm x 24cm)
 - IAP-274 (with aesthetic cover): 7.5 inches x 9 inches x 9.4 inches (19cm x 23cm x 24cm)
 - IAP-275: 10.6 inches x 9 inches x 9.4 inches (27cm x 23cm x 24cm)
- Weight
 - IAP-274(without aesthetic cover): 5.3 lbs/2.4 kg
 - IAP-274 (with aesthetic cover): 6lbs/2.7kg
 - IAP-275: 5.3 lbs/2.4 kg

Electrical

- Ethernet
 - 2 x 10/100/1000Base-T auto-sensing Ethernet RJ-45 Interfaces
 - MDI/MDX
 - Power over Ethernet (IEEE 802.3at compliant), 48VDC/0.6A
- Power
 - 100-240 VAC 50/60 Hz from external AC power source
 - POE support on WAN port: 802.3at-compliant POE sourcing devices

Environmental

- Operating
 - Temperature: -40°C to 65°C (-40°F to 150°F)
 - Humidity: 5% to 95% non-condensing
- Storage
 - Temperature: -40°C to 70°C (-40°F to 158°F)

For additional specifications on this product, please refer to the data sheet. The data sheet can be found at www.arubanetworks.com.

Safety and Regulatory Compliance

Aruba Networks provides a multi-language document that contains country-specific restrictions and additional safety and regulatory information for all Aruba access points. This document can be viewed or downloaded from the following location: www.arubanetworks.com/safety_addendum

Regulatory Model Name

The following regulatory model names apply to the IAP-270 Series:

- IAP-274: APEX0101
- IAP-275: APEX0100

FCC

This device is electronically labeled. To view the FCC ID:

1. Log into the controller WebUI
2. Navigate to **Maintenance > Controller > About**.



Aruba access points must be installed by a professional installer. The professional installer is responsible for ensuring that grounding is available and it meets applicable local and national electrical codes.



RF Radiation Exposure Statement: This equipment complies with FCC RF radiation exposure limits. This equipment should be installed and operated with a minimum distance of 13.78 inches (35 cm) between the radiator and your body for 2.4 GHz and 5 GHz operations. This transmitter must not be co-located or operating in conjunction with any other antenna or transmitter. When operated in the 5.15 to 5.25 GHz frequency range, this device is restricted to indoor use to reduce the potential for harmful interference with co-channel Mobile Satellite Systems.

FCC Class B Part 15

This device complies with Part 15 of the Federal Communications Commission (FCC) Rules. Operation is subject to the following two conditions:

- This device may not cause harmful interference.
- This device must accept any interference received, including interference that may cause undesired operation.



Changes or modifications to this unit not expressly approved by the party responsible for compliance could void the user's authority to operate this equipment.

This equipment has been tested and found to comply with the limits for a Class B digital device, pursuant to Part 15 of the FCC Rules. This equipment generates, uses and can radiate radio frequency energy and, if not installed and used in accordance with the manufacturer's instructions, may cause interference harmful to radio communications.

If this equipment does cause interference, which can be determined by turning the equipment off and on, the user is encouraged to try to correct the interference by one or more of the following measures:

- Reorient or relocate the receiving antenna.
- Increase the separation between the equipment and receiver.
- Connect the equipment to an outlet on a circuit different from that to which the receiver is connected.
- Consult the dealer or an experienced radio or TV technician for help.

CE EU Regulatory Conformance

Aruba Networks, Inc., hereby declares that the APEX0101 and APEX0100 device models are in compliance with the essential requirements and other relevant provisions of Directive 1999/5/EC -CE(!). The Declaration of Conformity made under Directive 1999/5/EC is available for viewing at www.arubanetworks.com.

Proper Disposal of Aruba Equipment

For the most current information about Global Environmental Compliance and Aruba products, see our website at www.arubanetworks.com.

Waste of Electrical and Electronic Equipment



Aruba products at end of life are subject to separate collection and treatment in the EU Member States, Norway, and Switzerland and therefore are marked with the symbol shown at the left (crossed-out wheeled bin). The treatment applied at end of life of these products in these countries shall comply with the applicable national laws of countries implementing Directive 2002/96/EC on Waste of Electrical and Electronic Equipment (WEEE).

European Union RoHS



Aruba products also comply with the EU Restriction of Hazardous Substances Directive 2011/65/EC (RoHS). EU RoHS restricts the use of specific hazardous materials in the manufacture of electrical and electronic equipment. Specifically, restricted materials under the RoHS Directive are Lead (including Solder used in printed circuit assemblies), Cadmium, Mercury, Hexavalent Chromium, and Bromine. Some Aruba products are subject to the exemptions listed in RoHS Directive Annex 7 (Lead in solder used in printed circuit assemblies). Products and packaging will be marked with the “RoHS” label shown at the left indicating conformance to this Directive.

China RoHS



Aruba products also comply with China environmental declaration requirements and are labeled with the “EFUP 10” label shown at the left.

有毒有害物质声明 Hazardous Materials Declaration

部件名称 (Parts)	有毒有害物质或元素 (Hazardous Substance)					
	铅 (Pb)	汞 (Hg)	镉 (Cd)	六价铬 (Cr ⁶⁺)	多溴联苯 (PBB)	多溴二苯醚 (PBDE)
电路板 (PCA Boards)	×	○	○	○	○	○
机械组件 (Mechanical Sub-Assemblies)	×	○	○	○	○	○

○: 表示该有毒有害物质在该部件所有均质材料中的含量均在 SJ/T11363-2006 标准规定的限量要求以下。
Indicates that the concentration of the hazardous substance in all homogeneous materials in the parts is below the relevant threshold of the SJ/T11363-2006 standard.

×: 表示该有毒有害物质至少在该部件的某一均质材料中的含量超出 SJ/T11363-2006 标准规定的限量要求。
Indicates that the concentration of the hazardous substance of at least one of all homogeneous materials in the parts is above the relevant threshold of the SJ/T11363-2006 standard.

对销售之日的所售产品, 本表显示, 供应链的电子产品信息产品可能包含这些物质。
This table shows where these substances may be found in the supply chain of electronic information products, as of the date of sale of the enclosed product.

此标志为针对所涉及产品的环保使用期标志。某些零部件会有一个不同的环保使用期 (例如, 电池单元模块) 贴在其产品上。
此环保使用期限只适用于产品是在产品手册中所规定的条件下工作。
The Environment-Friendly Use Period (EFUP) for all enclosed products and their parts are per the symbol shown here. The Environment-Friendly Use Period is valid only when the product is operated under the conditions defined in the product manual.



Canadian Statement

Under Industry Canada regulations, this radio transmitter may only operate using an antenna of a type and maximum (or lesser) gain approved for the transmitter by Industry Canada. To reduce potential radio interference to other users, the antenna type and its gain should be so chosen that the equivalent isotropically radiated power (e.i.r.p.) is not more than that necessary for successful communication.

This device complies with Industry Canada licence-exempt RSS standard(s).

Operation is subject to the following two conditions: (1) this device may not cause interference, and (2) this device must accept any interference, including interference that may cause undesired operation of the device.

Canadian Caution

This radio transmitter (identify the device by certification number, or model number if Category II) has been approved by Industry Canada to operate with the antenna types listed below with the maximum permissible gain and required antenna impedance for each antenna type indicated. Antenna types not included in this list, having a gain greater than the maximum gain indicated for that type, are strictly prohibited for use with this device.

Gain of antenna: 14.0dBi max/10dBi max;

Type of antenna: directional/omni;

Impedance of antenna: 50ohm

Le présent émetteur radio (identifier le dispositif par son numéro de certification ou son numéro de modèle s'il fait partie du matériel de catégorie I) a été approuvé par Industrie Canada pour fonctionner avec les types d'antenne énumérés ci-dessous et ayant un gain admissible maximal et l'impédance requise pour chaque type d'antenne. Les types d'antenne non inclus dans cette liste, ou dont le gain est supérieur au gain maximal indiqué, sont strictement interdits pour l'exploitation de l'émetteur.

Gain d'antenne: 14.0dBi maximal/10dBi maximal;

Type d'antenne: 50 ohm, directionnel/omni.

Philippines (IAP-274)



NTC

Type-Approval No.
ESD-1408699C

Philippines (IAP-275)



NTC

Type-Approval No.
ESD-1408698C

Hong Kong (IAP-274)



Hong Kong (IAP-275)



UAE (IAP-274)

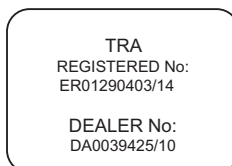

UAE (IAP-275)

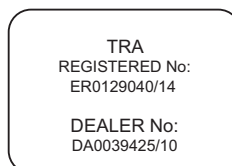

Singapore (IAP-274 and IAP-275)

Complies with
IDA Standards
DB101525

This page is intentionally left blank.

Contacting Aruba Networks

Website Support	
Main Site	arubanetworks.com
Support Site	support.arubanetworks.com
Airheads Social Forums and Knowledge Base	community.arubanetworks.com
North American Telephone	1-800-943-4526 (Toll Free) 1-408-754-1200
International Telephones	arubanetworks.com/support-services/contact-support/
Software Licensing Site	licensing.arubanetworks.com/
End of Support Information	arubanetworks.com/support-services/end-of-life-products/end-of-life-policy/
Security Incident Response Team (SIRT)	arubanetworks.com/support-service/security-bulletins/
Support Email Addresses	
Americas, EMEA, and APAC	support@arubanetworks.com
Security Incident Response Team (SIRT)	sirt@arubanetworks.com

Open Source Code

This product includes code licensed under the GNU General Public License, the GNU Lesser General Public License, and/or certain other open source licenses. A complete machine-readable copy of the source code corresponding to such code is available upon request. This offer is valid to anyone in receipt of this information and shall expire three years following the date of the final distribution of this product version by Hewlett Packard Enterprise Company. To obtain such source code, send a check or money order in the amount of US \$10.00 to:

Hewlett Packard Enterprise Company
Attn: General Counsel
3000 Hanover Street
Palo Alto, CA 94304
USA

Warranty

This hardware product is protected by an Aruba warranty. For details, see Aruba Networks standard warranty terms and conditions.

© Copyright 2017 Hewlett Packard Enterprise Development LP



aruba

a Hewlett Packard
Enterprise company

www.arubanetworks.com

3333 Scott Blvd
Santa Clara, CA 95054

Phone: +1 408 227 4500
Fax: +1 408 752 0626