

System x3550 M4 (E5-2600) Product Guide (withdrawn product)

The System x3550 M4 server provides outstanding performance for your business-critical applications. Its energy-efficient design supports more cores, memory, and data capacity in a compact 1U package that is easy to service and manage. With more computing power per watt and the latest Intel Xeon processors, you can reduce costs while maintaining speed and availability.

Suggested use: database, virtualization, enterprise applications, collaboration/email, streaming media, web, HPC, and cloud applications.

Figure 1 shows the System x3550 M4.



Figure 1. System x3550 M4

Did you know?

The x3550 M4 offers a flexible, scalable design and a simple upgrade path to eight HDDs plus an optical drive at the same time, and up to 768 GB of memory. The flexible onboard Ethernet solution provides four standard integrated Gigabit Ethernet ports and two optional embedded 10 Gb Ethernet ports without occupying PCIe slots. Comprehensive systems management tools with the next-generation Integrated Management Module II (IMM2) make it easy to deploy, integrate, service, and manage.

Key features

The x3550 M4 is a cost- and density-balanced 1U, 2-socket business-critical server, offering improved performance and pay-as-you grow flexibility along with new features that improve server management capability. The powerful system is designed for your most important business applications and cloud deployments.

Combining balanced performance and flexibility, the x3550 M4 is a great choice for small and medium businesses and up to the large enterprise. It can provide outstanding uptime to keep business-critical applications and cloud deployments running safely. Ease-of-use and comprehensive systems management tools make it easy to deploy. Outstanding RAS and high-efficiency design improves your business environment and helps save operational costs.

Scalability and performance

The x3550 M4 offers numerous features to boost performance, improve scalability, and reduce costs:

- Intel Xeon processor E5-2600 product family
 - Improves productivity by offering superior system performance with up to 8-core processors, up to 20 MB of L3 cache, and up to two 8 GT/s QPI interconnect links.
 - Supports up to two processors, 16 cores, and 32 threads maximize the concurrent execution of multi-threaded applications.
 - Supports up to 1600 MHz memory speeds.
 - Supports up to 768 GB memory with 32 GB LRDIMMs.
- Intelligent and adaptive system performance with Intel Turbo Boost Technology 2.0 allows CPU cores to run at maximum speeds during peak workloads by temporarily going beyond processor thermal design power (TDP).
- Intel Hyper-Threading Technology boosts performance for multithreaded applications by enabling simultaneous multithreading within each processor core, up to two threads per core.
- Intel Virtualization Technology integrates hardware-level virtualization hooks that allow operating system vendors to better utilize the hardware for virtualization workloads.
- Intel Advanced Vector Extensions (AVX) significantly improve floating point performance for compute-intensive technical and scientific applications compared to Intel Xeon 5600 series processors.
- 12 Gbps SAS internal storage connectivity doubles the data transfer rate compared to 6 Gb SAS solutions to maximize performance of storage I/O-intensive applications.
- The use of solid-state drives (SSDs) instead of or along with traditional spinning drives (HDDs) can significantly improve I/O performance. An SSD can support up to 100 times more I/O operations per second (IOPS) than a typical HDD.
- The server has four integrated Gigabit Ethernet ports and two optional 10 Gb Ethernet ports with mezzanine cards that do not consume a PCIe slot.
- The server offers PCI Express (PCIe) 3.0 I/O expansion capabilities that improve the theoretical maximum bandwidth by almost 100% (8 GTps per link using 128b/130b encoding) compared to the previous generation of PCI Express 2.0 (5 GTps per link using 8b/10b encoding).
- With Intel Integrated I/O Technology, the PCI Express 3.0 controller is integrated into the Intel Xeon processor E5 family. This helps to dramatically reduce I/O latency and increase overall system performance.
- Support for NVIDIA Quadro graphics processing units (GPUs) to maximize computing power.

Availability and serviceability

The x3550 M4 provides many features to simplify serviceability and increase system uptime:

- The server offers memory mirroring and memory rank sparing for redundancy in the event of a non-correctable memory failure.
- Tool-less cover removal provides easy access to upgrades and serviceable parts, such as CPU, memory, and adapter cards.

- The server offers hot-swap drives supporting RAID redundancy for data protection and greater system uptime.
- The server has two redundant hot-swap power supplies and six dual-motor hot-swap redundant fans (two fan zones with N+1 fan design) to provide availability for business-critical applications.
- The power source-independent light path diagnostics panel and individual light path LEDs quickly lead the technician to failed (or failing) components. This simplifies servicing, speeds up problem resolution, and helps improve system availability.
- Predictive Failure Analysis (PFA) detects when system components (processors, VRMs, memory, hard disk drives, fans, and power supplies) operate outside of standard thresholds and generates proactive alerts in advance of possible failure, therefore increasing uptime.
- Solid-state drives (SSDs) offer significantly better reliability than traditional mechanical HDDs for greater uptime.
- Built-in Integrated Management Module II (IMM2) continuously monitors system parameters, triggers alerts, and performs recovery actions in case of failure, to minimize downtime.
- Built-in diagnostics using Dynamic Systems Analysis (DSA) Preboot speeds up troubleshooting tasks to reduce service time.
- Three-year customer replaceable unit and onsite limited warranty, next business day 9x5. Optional service upgrades available.

Manageability and security

Powerful systems management features simplify local and remote management of the x3550 M4:

- The server includes an Integrated Management Module II (IMM2) to monitor server availability and perform remote management.
- An integrated industry-standard Unified Extensible Firmware Interface (UEFI) enables improved setup, configuration, and updates, and simplifies error handling.
- An integrated Trusted Platform Module (TPM) 1.2 support enables advanced cryptographic functionality such as digital signatures and remote attestation.
- There is industry-standard AES NI support for faster, stronger encryption.
- IBM Systems Director offers comprehensive systems management tools that help to increase uptime, reduce costs and improve productivity through advanced server management capabilities.
- Intel Execute Disable Bit functionality can help prevent certain classes of malicious buffer overflow attacks when combined with a supporting operating system.
- Intel Trusted Execution Technology provides enhanced security through hardware-based resistance to malicious software attacks, allowing an application to run in its own isolated space protected from all other software running on a system.

Energy efficiency

The x3550 M4 offers the following energy-efficiency features to save energy, reduce operational costs, increase energy availability, and contribute to a green environment:

- Energy-efficient planar components help lower operational costs.
- The x3550 M4 is Energy Star 2.0 compliant. Energy Star is the trusted, US government-backed symbol for energy efficiency, with the goal of helping customers save money and protect the environment through energy efficient products and practices.
- High-efficiency 550 W and 750 W power supplies with 80 PLUS Platinum certification. Available 750 W dc power supply option.
- The Intel Xeon processor E5-2600 product family offers significantly better performance over the previous generation, while fitting into the same TDP limits.
- Intel Intelligent Power Capability powers individual processor elements on and off as needed, to reduce power draw.

- Low-voltage Intel Xeon processors draw less energy to satisfy the demands of power and thermally constrained data centers and telecommunication environments.
- Low-voltage 1.35 V DDR3 memory RDIMMs consume up to 19% less energy compared to 1.5 V DDR3 RDIMMs.
- Solid-state drives (SSDs) consume as much as 80% less power than traditional spinning 2.5-inch HDDs.
- The server uses hexagonal ventilation holes, a part of Calibrated Vectors Cooling™ technology. Hexagonal holes can be grouped more densely than round holes, providing more efficient airflow through the system.
- IBM Systems Director Active Energy Manager™ provides advanced data center power notification and management to help achieve lower heat output and reduced cooling needs.

Components and connectors

Figure 2 shows the front of the server.

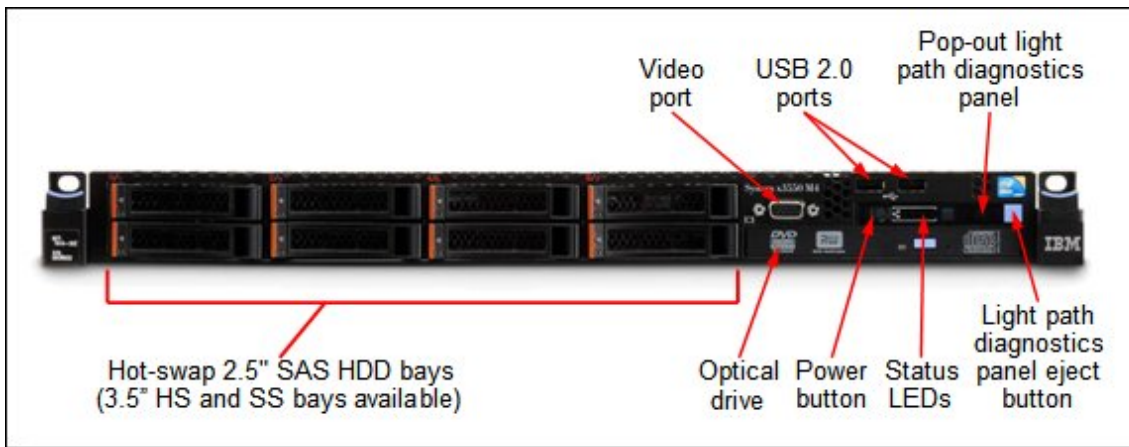

Figure 2. Front view of the System x3550 M4

Figure 3 shows the rear of the server.

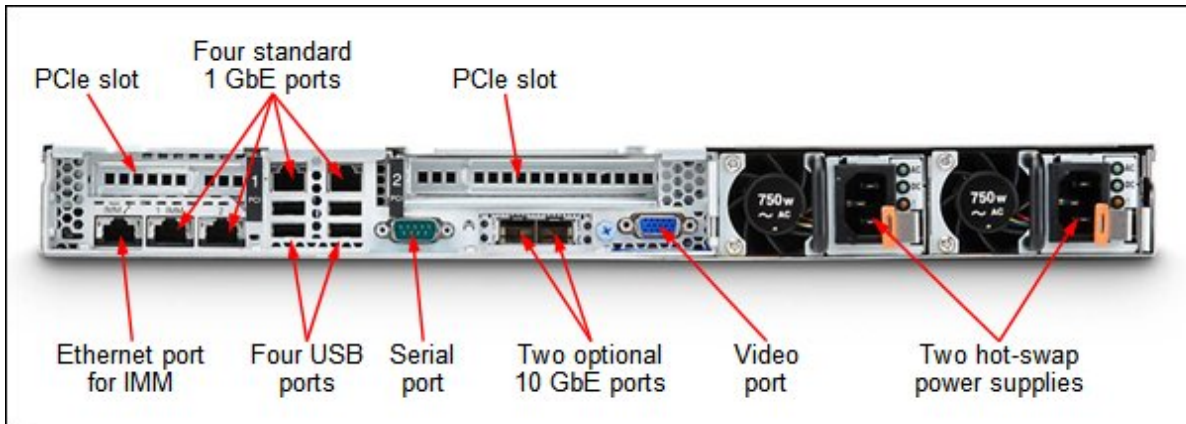

Figure 3. Rear view of the System x3550 M4

Figure 4 shows the locations of key components inside the server.

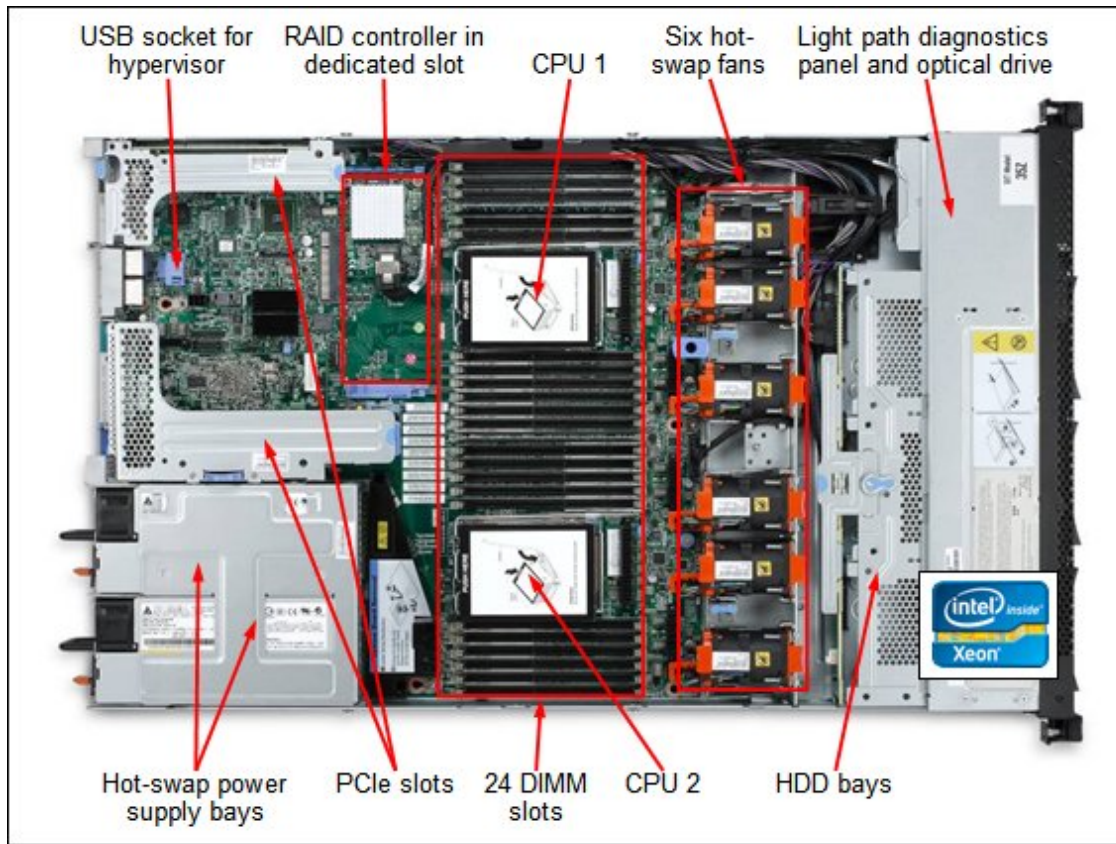

Figure 4. Inside view of the System x3550 M4

Standard specifications

The following table lists the standard specifications.

Table 1. Standard specifications

Components	Specification
Form factor	1U Rack-mount.
Processor	Up to two Intel Xeon processor E5-2600 product family CPUs with eight cores (up to 2.9 GHz) or six cores (up to 2.9 GHz) or quad-cores (up to 3.3 GHz). Two QPI links up to 8.0 GT/s each. Up to 1600 MHz memory speed. Up to 20 MB L3 cache.
Chipset	Intel C604
Memory	Up to 24 DIMM sockets (12 DIMMs per processor). RDIMMs, UDIMMs and LR-DIMMs (Load Reduced DIMMs) are supported but memory types cannot be intermixed. Memory DIMM speeds up to 1600 MHz.
Memory maximums	<ul style="list-style-type: none"> ● RDIMMs: Up to 384 GB with 24x 16 GB RDIMMs and two processors ● UDIMMs: Up to 64 GB with 16x 4 GB UDIMMs and two processors ● LRDIMMs: Up to 768 GB with 24x 32 GB LRDIMMs and two processors
Memory protection	ECC, Chipkill (for x4-based memory DIMMs), memory mirroring, and memory rank sparing.
Disk drive bays	Up to eight 2.5" hot-swap SAS/SATA HDDs, or up to three 3.5" hot-swap SAS/SATA HDDs, or up to three 3.5" Simple Swap SATA HDDs.
Maximum internal storage	Up to 14.4 TB with 1.8 TB 2.5" SAS HDDs, or up to 8 TB with 1 TB 2.5" NL SAS/SATA HDDs, or up to 12.8 TB with 1.6 TB 2.5" SAS/SATA SSDs, or up to 18 TB with 6 TB 3.5" NL SAS/SATA HDDs. Intermix of SAS/SATA is supported.
RAID support	<ul style="list-style-type: none"> ● 6 Gb SAS/SATA: RAID 0, 1, 10 with H1110, M1115 or M5110. Optional upgrades to RAID 5, 50 available for M1115. Optional upgrades to RAID 5, 50 are available for M5110 (zero-cache; 512 MB battery-backed cache; 512 MB or 1 GB flash-backed cache). Optional upgrade to RAID 6, 60 are available for M5110 with 512 MB or 1 GB cache upgrades. ● 12 Gb SAS/SATA: RAID 0, 1, 10 with optional M5210. Optional upgrades to RAID 5, 50 are available for M5210 (zero-cache; 1 GB non-backed cache; 1 GB or 2 GB flash-backed cache). Optional upgrade to RAID 6, 60 are available for M5210 with 1 GB or 2 GB cache upgrades.
Optical drive bays	One, optional, for models with 2.5" drives. Support for DVD-ROM or Multiburner.
Tape drive bays	None.
Network interfaces	Four integrated Gigabit Ethernet 1000BASE-T ports (RJ-45); two integrated 10 Gb Ethernet ports (10GBASE-T RJ-45 or 10GBASE-SR SFP+ based) on optional 10 Gb Ethernet mezzanine card (does not consume a PCIe slot).
PCI Expansion slots	Two slots, depending on the riser cards installed. The slots are as follows (all PCIe slots are PCIe 3.0, all PCI-X slots are 64 bit/133 MHz): <ul style="list-style-type: none"> ● Slot 1: PCIe x16; low profile, half-length ● Slot 2: PCIe x8, opt. PCI-X or PCIe x16; full-height/half-length (PCIe x16 req. 2nd CPU) Additional dedicated slot for ServeRAID adapter.
Ports	Two USB 2.0 (three USB 2.0 for 3.5" HDD models) and one DB-15 video on front. Four USB 2.0, one DB-15 video, one DB-9 serial, one RJ-45 systems management, four RJ-45 GbE network ports, two optional RJ-45 or SFP+ 10 GbE network ports on rear. One internal USB ports (for embedded hypervisor).
Cooling	Calibrated Vectored Cooling™ with up to six N+1 redundant hot-swap fans (four standard, additional two with second processor or with the x3550 M4 Thermal Solution Kit); two fan zones with N+1 fan design; each fan has two motors.

Components	Specification
Power supply	Up to two redundant hot-swap 550 W AC or 750 W AC power supplies (80+ Platinum certification), or 750 W DC power supply options.
Hot-swap parts	Hard drives, power supplies, fans.
Systems management	UEFI, Integrated Management Module 2 (IMM2), Predictive Failure Analysis, Light Path Diagnostics, Automatic Server Restart, IBM Systems Director and IBM Systems Director Active Energy Manager™, ServerGuide. Optional Advanced Management Module Advanced Upgrade (FoD) for remote presence (graphics, keyboard and mouse, virtual media).
Security features	Power-on password, administrator's password, Trusted Platform Module (TPM).
Video	Matrox G200eR2 with 16 MB memory integrated into the IMM2. Maximum resolution is 1600x1200 at 75 Hz with 16 M colors.
Operating systems supported	Microsoft Windows Server 2012 R2, 2012, 2008 R2 and 2008; Red Hat Enterprise Linux (RHEL) 5, 6, and 7; SUSE Linux Enterprise Server (SLES) 10, 11, and 12; VMware ESX 4.1 and ESXi 4.1, VMware vSphere (ESXi) 5.0, 5.1, and 5.5.
Limited warranty	Three-year customer-replaceable unit and onsite limited warranty with 9x5/NBD.
Service and support	Optional service upgrades are available through Lenovo Services: 4-hour or 2-hour response time, 8 hours fix time, one-year or two-year warranty extension, remote technical support for System x hardware and selected third-party (Microsoft, Linux, VMware) software.
Dimensions	Height: 43 mm (1.7 in), width: 429 mm (16.9 in), depth: 734 mm (28.9 in)
Weight	Minimum configuration: 12.7 kg (28 lb), maximum: 15.9 kg (35.1 lb)

The x3550 M4 servers are shipped with the following items:

- Statement of Limited Warranty
- Important Notices
- Rack Installation Instructions
- Documentation CD containing *Installation and User's Guide*
- IBM Systems Director Flyer
- System x Gen-III Slides Kit
- System x Gen-III Cable Management Arm (CMA)
- 2.8 m C13-C14 power cord (one for models with one power supply and two for models with two power supplies)

Standard models

The following table lists the standard models.

Table 2. Standard models

Model number	Intel Xeon Processors† (2 maximum)	Memory	RAID	Disk bays	Disks	GbE	Optical	Power
Models announced August 2012								
791432x	1x E5-2643 4C 3.3GHz 10MB 1600MHz 130W	1x 4 GB	M5110	4x 2.5" HS/8	Open	4	Open	1x 750W
7914DDx*	2x E5-2620 6C 2.0GHz 15MB 1333MHz 95W	8x 4 GB	M5110 512MB with Battery	4x 2.5" HS/8	2x 600 GB SAS	6*	Multi- burner	2x 550W
7914M2x	1x E5-2690 8C 2.9GHz 20MB 1600MHz 135W	1x 4 GB	M5110	4x 2.5" HS/8	Open	4	Open	1x 750W
Models announced March 2012								
7914A2x	1x E5-2603 4C 1.8GHz 10MB 1066MHz 80W	1x 4 GB	H1110	4x 2.5" HS/8	Open	4	Open	1x 550W
7914B2x	1x E5-2609 4C 2.4GHz 10MB 1066MHz 80W	1x 4 GB	M1115	4x 2.5" HS/8	Open	4	Open	1x 550W
7914C2x	1x E5-2620 6C 2.0GHz 15MB 1333MHz 95W	1x 8 GB	M1115	4x 2.5" HS/8	Open	4	Open	1x 550W
7914C4x	1x E5-2620 6C 2.0GHz 15MB 1333MHz 95W	1x 8 GB	H1110	3x 3.5" HS/6	Open	4	None	1x 550W
7914D2x	1x E5-2630 6C 2.3GHz 15MB 1333MHz 95W	1x 8 GB	M5110 512MB+Flash	4x 2.5" HS/8	Open	4	Open	1x 550W
7914F2x	1x E5-2640 6C 2.5GHz 15MB 1333MHz 95W	1x 8 GB	M5110 512MB+Flash	4x 2.5" HS/8	Open	4	Open	1x 550W
7914G2x	1x E5-2650 8C 2.0GHz 20MB 1600MHz 95W	1x 8 GB	M5110 1GB+Flash	4x 2.5" HS/8	Open	4	Open	1x 550W
791452x	1x E5-2650L 8C 1.8GHz 20MB 1600MHz 70W	1x 8 GB	M5110 1GB+Flash	4x 2.5" HS/8	Open	4	Open	1x 550W
7914H2x	1x E5-2660 8C 2.2GHz 20MB 1600MHz 95W	1x 8 GB	M5110 1GB+Flash	4x 2.5" HS/8	Open	4	Open	1x 550W
791462x	1x E5-2665 8C 2.4GHz 20MB 1600MHz 115W	1x 8 GB	M5110 1GB+Flash	4x 2.5" HS/8	Open	4	Open	1x 550W
7914J2x	1x E5-2670 8C 2.6GHz 20MB 1600MHz 115W	1x 8 GB	M5110 1GB+Flash	4x 2.5" HS/8	Open	4	Open	1x 550W
7914L2x	1x E5-2680 8C 2.7GHz 20MB 1600MHz 130W	1x 8 GB	M5110 1GB+Flash	4x 2.5" HS/8	Open	4	Open	1x 750W

† Processor detail: Processor quantity and model, core speed, number of cores, L3 cache, memory speed.

* Model 7914DDx is a management server for offerings such as cloud.

Management node

Model 7914DDx is a model optimized as a management node and is preloaded with Windows Server 2008 R2 Standard and IBM Systems Director.

The model also includes these components as standard:

- Intel Ethernet Dual Port Server Adapter I340-T2 (49Y4230)
- Integrated Management Module Advanced Upgrade (90Y3901)
- Two PCIe x16 slots

Express models

The following table lists the Express models.

Table 3. Express models

Model	Intel Xeon Processors† (2 maximum)	Memory	RAID	Disk bays	Disks	GbE	DVD	Power
United States, Canada, and Latin America								
7914EAU	1x E5-2609 4C 2.4GHz 10MB 1066MHz 80W	1x 4 GB	M1115	4x 2.5" HS / 8	Optional	4	Multi-burner	1x 550W
7914EBU	1x E5-2620 6C 2.0GHz 15MB 1333MHz 95W	1x 8GB	M5110 512MB Flash	4x 2.5" HS / 8	Optional	4	Multi-burner	1x 550W
7914ECU	1x E5-2630 6C 2.3GHz 15MB 1333MHz 95W	1x 8GB	M5110 512MB Flash	4x 2.5" HS / 8	Optional	4	Multi-burner	1x 550W
7914EDU	1x E5-2650 8C 2.0GHz 20MB 1600MHz 95W	1x 8GB	M5110 1GB Flash	4x 2.5" HS / 8	Optional	4	Multi-burner	1x 550W
Europe								
7914E1G	1x E5-2603 4C 1.8GHz 10MB 1066MHz 80W	1x 4 GB	M1115	4x 2.5" HS / 8	Optional	4	Multi-burner	1x 550W
7914E2G	1x E5-2603 4C 1.8GHz 10MB 1066MHz 80W	1x 4 GB	M1115	4x 2.5" HS / 8	2 x 500GB HS SATA	4	Multi-burner	1x 550W
7914E3G	1x E5-2620 6C 2.0GHz 15MB 1333MHz 95W	1x 8 GB	M5110 512MB Cache	8x 2.5" HS / 8	Optional	4	Multi-burner	1x 550W
7914E4G	1x E5-2620 6C 2.0GHz 15MB 1333MHz 95W	1x 8 GB	M1115	3x 3.5" HS/ 3	Optional	4	None	1x 550W
7914E5G	1x E5-2630 6C 2.3GHz 15MB 1333MHz 95W	1x 8 GB	M5110 512MB Flash	4x 2.5" HS / 8	2 x 300GB 10K HS SAS	4	Multi-burner	2x 550W
Central and Eastern Europe and Middle East & Africa								
7914E1G	1x E5-2603 4C 1.8GHz 10MB 1066MHz 80W	1x 4 GB	M1115	4x 2.5" HS / 8	Optional	4	Multi-burner	1x 550W
7914E2G	1x E5-2603 4C 1.8GHz 10MB 1066MHz 80W	1x 4 GB	M1115	4x 2.5" HS / 8	2 x 500GB HS SATA	4	Multi-burner	1x 550W
7914E3G	1x E5-2620 6C 2.0GHz 15MB 1333MHz 95W	1x 8 GB	M5110 512MB Cache	8x 2.5" HS / 8	Optional	4	Multi-burner	1x 550W
7914E4G	1x E5-2620 6C 2.0GHz 15MB 1333MHz 95W	1x 8 GB	M1115	3x 3.5" HS/ 3	Optional	4	None	1x 550W
7914E5G	1x E5-2630 6C 2.3GHz 15MB 1333MHz 95W	1x 8 GB	M5110 512MB Flash	4x 2.5" HS / 8	2 x 300GB 10K HS SAS	4	Multi-burner	2x 550W
7914K2G	1x E5-2620 6C 2.0GHz 15MB 1333MHz 95W	1x 8 GB	M5110 512MB Flash	3x 3.5" HS/ 3	Optional	4	None	1x 550W
7914K3G	1x E5-2630 6C 2.3GHz 15MB 1333MHz 95W	2x 8 GB	M5110 512MB Flash	8x 2.5" HS / 8	Optional	4	Multi-burner	2x 550W
Russia/Commonwealth of Independent States (CIS)								
7914E1G	1x E5-2603 4C 1.8GHz 10MB 1066MHz 80W	1x 4 GB	M1115	4x 2.5" HS / 8	Optional	4	Multi-burner	1x 550W
7914K1G	1x E5-2620 6C 2.0GHz 15MB 1333MHz 95W	1x 8 GB	M5110 512MB Flash	8x 2.5" HS / 8	Optional	4	Multi-burner	1x 550W
7914K2G	1x E5-2620 6C 2.0GHz 15MB 1333MHz 95W	1x 8 GB	M5110 512MB Flash	3x 3.5" HS/ 3	Optional	4	None	1x 550W
7914K3G	1x E5-2630 6C 2.3GHz 15MB 1333MHz 95W	2x 8 GB	M5110 512MB Flash	8x 2.5" HS / 8	Optional	4	Multi-burner	2x 550W

† Processor detail: Processor quantity and model, core speed, number of cores, L3 cache, memory speed.

Processor options

The x3550 M4 supports the processor options listed in the following table. The server supports up to two processors. This table shows which server models have each processor standard. If there is no corresponding *where used* model for a particular processor, then this processor is only available through CTO. The part numbers include two system fans.

Table 4. Processor options

Part number	Feature codes*	Description	Standard models where used
Intel Xeon processor E5-2600 product family			
69Y5672	A1LG / A1LT	Intel Xeon E5-2603 4C 1.8GHz 10MB 1066MHz 80W	A2x
69Y5674	A1LJ / A1LV	Intel Xeon E5-2609 4C 2.4GHz 10MB 1066MHz 80W	B2x
69Y5675	A1LK / A1LW	Intel Xeon E5-2620 6C 2.0GHz 15MB 1333MHz 95W	C2x, C4x, DDx
69Y5676	A1LL / A1LX	Intel Xeon E5-2630 6C 2.3GHz 15MB 1333MHz 95W	D2x
94Y7464	A2B3 / A2B6	Intel Xeon E5-2630L 6C 2.0GHz 15MB 1333MHz 60W	-
94Y7546	A2VR / A2QK	Intel Xeon E5-2637 2C 3.0GHz 5MB 1600MHz 80W	-
69Y5677	A1LM / A1LY	Intel Xeon E5-2640 6C 2.5GHz 15MB 1333MHz 95W	F2x
94Y7465	A2B4 / A2B7	Intel Xeon E5-2643 4C 3.3GHz 10MB 1600MHz 130W	32x
00D9441	A39A / A39D	Intel Xeon E5-2648L 8C 1.8GHz 20MB 1600MHz 70W	
69Y5678	A1LN / A1LZ	Intel Xeon E5-2650 8C 2.0GHz 20MB 1600MHz 95W	G2x
69Y5685	A1LS / A1M3	Intel Xeon E5-2650L 8C 1.8GHz 20MB 1600MHz 70W	52x
00D9440	A399 / A39C	Intel Xeon E5-2658 8C 2.1GHz 20MB 1600MHz 95W	
69Y5679	A1LP / A1M0	Intel Xeon E5-2660 8C 2.2GHz 20MB 1600MHz 95W	H2x
94Y7547	A2GN / A2GP	Intel Xeon E5-2665 8C 2.4GHz 20MB 1600MHz 115W	62x
69Y5682	A1LR / A1M2	Intel Xeon E5-2667 6C 2.9GHz 15MB 1600MHz 130W	-
94Y7463	A2B2 / A2B5	Intel Xeon E5-2670 8C 2.6GHz 20MB 1600MHz 115W	J2x
69Y5680	A1LQ / A1M1	Intel Xeon E5-2680 8C 2.7GHz 20MB 1600MHz 130W	L2x
94Y7545	A2VQ / A2QJ	Intel Xeon E5-2690 8C 2.9GHz 20MB 1600MHz 135W	M2x

* The first feature code is for the first processor; the second feature code is for the second processor

Memory options

System x DDR3 memory is compatibility tested and tuned for optimal System x performance and throughput. System x memory specifications are integrated into the light path diagnostics for immediate system performance feedback and optimum system uptime. From a service and support standpoint, System x memory automatically assumes the system's warranty, and Lenovo provides service and support worldwide.

The System x3550 M4 supports DDR3 memory. The server supports up to 12 DIMMs when one processor is installed, and up to 24 DIMMs when two processors are installed. Each processor has four memory channels, and there are three DIMMs per channel.

The following rules apply when selecting the memory configuration:

- Server supports UDIMMs, RDIMMs, and LRDIMMs.
- Mixing different types of memory (UDIMMs, RDIMMs, and LRDIMMs) is not supported.
- Mixing 1.5 V and 1.35 V DIMMs in the same server is supported; in such cases, all DIMMs operate at 1.5 V.
- The maximum number of ranks supported per one channel is eight (with the exception of Load Reduced DIMMs, where more than eight ranks are supported because one quad-rank LRDIMM provides the same electrical load on a memory bus as a single-rank RDIMM).
- The maximum quantity of DIMMs that can be installed in server depends on number of CPUs, DIMM type, rank, and operating voltage as shown in the "Maximum quantity" row in the following table.
- All DIMMs in all CPU memory channels operate at the same speed, which is determined as the lowest value of:
 - The memory speed supported by the specific CPU.
 - The lowest of maximum operating speeds for the selected memory configuration that depends on rated speed, operating voltage, and quantity of DIMMs per channel, as shown under "Maximum operating speed" section in the following table.

The following table (Parts 1 and 2) shows the characteristics of the supported DIMMs. Tables cells highlighted with a gray background indicate when the combination of DIMM voltage and the number of DIMMs per channel still allows the DIMMs to operate at a rated speed.

Table 5. Maximum memory speeds (Part 1: Intel Xeon processor E5-2600 product family - RDIMMs)

Specification	RDIMMs							
	Single rank			Dual rank			Quad rank	
Part numbers	49Y1405 (2 GB) 49Y1406 (4 GB)		49Y1559 (4 GB)	49Y1407 (4 GB) 49Y1397 (8 GB) 49Y1563 (16 GB)		90Y3178 (4 GB) 90Y3109 (8 GB) 00D4968 (16 GB)		49Y1399 (8 GB)
Rated speed	1333 MHz		1600 MHz	1333 MHz		1600 MHz		1066 MHz
Rated voltage	1.35 V		1.5 V	1.35 V		1.5 V		1.35 V
Operating voltage	1.35 V	1.5 V	1.5 V	1.35 V	1.5 V	1.5 V	1.35 V	1.5 V
Maximum quantity*	16	24	24	16	24	24	16	16
Largest DIMM	4 GB	4 GB	4 GB	16 GB	16 GB	16 GB	8 GB	8 GB
Maximum memory capacity	64 GB	96 GB	96 GB	256 GB	384 GB	384 GB	128 GB	128 GB
Maximum memory at rated speed	64 GB	64 GB	64 GB	256 GB	256 GB	256 GB	128 GB	64 GB
Maximum operating speed (MHz)								
1 DIMM per channel	1333 MHz	1333 MHz	1600 MHz	1333 MHz	1333 MHz	1600 MHz	800 MHz	1066 MHz
2 DIMMs per channel	1333 MHz	1333 MHz	1600 MHz	1333 MHz	1333 MHz	1600 MHz	800 MHz	800 MHz
3 DIMMs per channel	NS**	1066 MHz	1066 MHz	NS**	1066 MHz	1066 MHz	NS**	NS**

* Maximum quantity supported is shown for two processors installed. When one processor installed the maximum quantity supported is a half of shown.

** NS = Not Supported

Table 5. Maximum memory speeds (Part 2: Intel Xeon processor E5-2600 product family - UDIMMs and LRDIMMs)

Specification	UDIMMs		LRDIMMs	
Rank	Dual rank		Quad rank	
Part numbers	49Y1404 (4 GB)		90Y3105 (32 GB)	
Rated speed	1333 MHz		1333 MHz	
Rated voltage	1.35 V		1.35 V	
Operating voltage	1.35 V	1.5 V	1.35 V	1.5 V
Maximum quantity*	16	16	24	24
Largest DIMM	4 GB	4 GB	32 GB	32 GB
Maximum memory capacity	64 GB	64 GB	768 GB	768 GB
Maximum memory at rated speed	32 GB	64 GB	256 GB	512 GB
Maximum operating speed (MHz)				
1 DIMM per channel	1333 MHz	1333 MHz	1333 MHz	1333 MHz
2 DIMMs per channel	1066 MHz	1333 MHz	1066 MHz	1333 MHz
3 DIMMs per channel	Not supported	Not supported	1066 MHz	1066 MHz

* Maximum quantity supported is shown for two processors installed. When one processor installed the maximum quantity supported is a half of shown.

The following memory protection technologies are supported:

- ECC
- Chipkill (for x4-based memory DIMMs)
- Memory mirroring
- Memory rank sparing

If memory mirroring is used, then DIMMs must be installed in pairs (a minimum of one pair per each CPU), and both DIMMs in a pair must be identical in type and size.

If memory rank sparing is used, then a minimum of one quad-rank DIMM or two single-rank or dual-rank DIMMs must be installed per populated channel (the DIMMs do not need being identical). In rank sparing mode, one rank of a DIMM in each populated channel is reserved as spare memory. The size of a rank varies depending on the DIMMs installed.

The following table lists memory options available for the x3550 M4 server.

Table 6. Memory options

Part number	Feature code	Description	Maximum supported	Standard models where used
UDIMMs				
49Y1404	8648	4 GB (1x 4 GB, 2Rx8, 1.35 V) PC3L-10600 CL9 ECC 1333 MHz LP UDIMM	16 (8 per CPU)	-
RDIMMs - 1066 MHz and 1333 MHz				
49Y1405	8940	2 GB (1x 2 GB, 1Rx8, 1.35 V) PC3L-10600 CL9 ECC DDR3 1333 MHz LP RDIMM	24 (12 per CPU)	-
49Y1406	8941	4 GB (1x 4 GB, 1Rx4, 1.35 V) PC3L-10600 CL9 ECC DDR3 1333 MHz LP RDIMM	24 (12 per CPU)	A2x, B2x
49Y1407	8942	4 GB (1x 4 GB, 2Rx8, 1.35 V) PC3L-10600 CL9 ECC DDR3 1333 MHz LP RDIMM	24 (12 per CPU)	DDx
49Y1397	8923	8 GB (1x 8 GB, 2Rx4, 1.35 V) PC3L-10600 CL9 ECC 1333 MHz LP RDIMM	24 (12 per CPU)	C2x, C4x, D2x, F2x
49Y1399	A14E	8 GB (1x 8 GB, 4Rx8, 1.35 V) PC3L-8500 CL7 ECC DDR3 1066 MHz LP RDIMM	16 (8 per CPU)	-
49Y1563	A1QT	16 GB (1x 16 GB, 2Rx4, 1.35 V) PC3L-10600 CL9 ECC DDR3 1333 MHz LP RDIMM	24 (12 per CPU)	-
RDIMMs - 1600 MHz				
49Y1559	A28Z	4 GB (1x 4 GB, 1Rx4, 1.5 V) PC3-12800 CL11 ECC DDR3 1600 MHz LP RDIMM	24 (12 per CPU)	32x, M2x
90Y3178	A24L	4 GB (1x 4 GB, 2Rx8, 1.5 V) PC3-12800 CL11 ECC DDR3 1600 MHz LP RDIMM	24 (12 per CPU)	-
90Y3109	A292	8 GB (1x 8 GB, 2Rx4, 1.5 V) PC3-12800 CL11 ECC DDR3 1600 MHz LP RDIMM	24 (12 per CPU)	52x, 62x, G2x, H2x, J2x, L2x
00D4968	A2U5	16GB (1x16GB, 2Rx4, 1.5V) PC3-12800 CL11 ECC DDR3 1600MHz LP RDIMM	24 (12 per CPU)	-
LRDIMMs				
90Y3105	A291	32 GB (1x 32 GB, 4Rx4, 1.35 V) PC3L-10600 CL9 ECC DDR3 1333 MHz LP LRDIMM	24 (12 per CPU)	-

Internal storage

The System x3550 M4 server supports the following internal storage configurations:

- Eight 2.5" Slim-SFF SAS/SATA hot-swap hard drive bays
- Four 2.5" Slim-SFF SAS/SATA hot-swap hard drive bays
- Three 3.5" hot-swap SAS/SATA hard drive bays
- Three 3.5" Simple Swap SATA hard drive bays (only available in CTO)

Figure 5 shows the first three of these configurations.



Figure 5. Internal drive configurations

Backplanes

All standard models, except C4x, ship with four 2.5" Slim-SFF SAS/SATA hot-swap hard drive bays. Model C4x ships with three 3.5" SAS/SATA hot-swap hard drive bays. The following table shows the internal storage expansion options available for the x3550 M4 server.

Table 7. Internal storage expansion options

Part number	Feature code	Description	Maximum supported
6 Gbps drive backplane connectivity			
81Y6657	A1HN	x3550 M4 plus 4x 2.5" HDD Assembly Kit	1
12 Gbps drive backplane connectivity (support is planned for later in 2013)			
None*	A464	x3550M4 4x 2.5" HS HDD Assembly Kit for 12Gb RAID	1
00Y7297	A465	x3550M4 2.5" HDD Assembly Kit for 12Gb RAID	1
00Y8597	A4K4	x3550M4 mini-SAS Cable Kit for 12Gb RAID	1

* Available only via CTO or special bid.

Option 81Y6657 upgrades models with four hot-swap HDD bays to eight hot-swap HDD bays. Models A2x and A3x require H1110 to be replaced by M1115 or M5110 to support eight HDDs. An optical drive can be installed internally when this option is used.

Option 00Y7297 together with option 00Y8597 upgrades CTO models with four 12 Gb 2.5" hot-swap drive bays to eight 12 Gb hot-swap 2.5" drive bays.

Controllers for internal storage

The following table lists the RAID controllers and the additional options used for the internal disk storage of the x3550 M4 server. The controllers are installed into a dedicated PCIe slot.

Table 8. RAID controllers and HBAs for internal storage (Part 1: 6 Gbps SAS/SATA)

Part number	Feature code	Description	Maximum supported	Standard models where used
6 Gbps Controllers				
81Y4492	A1XL	ServeRAID H1110 SAS/SATA Controller	1	A2x, C4x
81Y4448	A1MZ	ServeRAID M1115 SAS/SATA Controller	1	B2x, C2x
81Y4481	A347	ServeRAID M5110 SAS/SATA Controller	1	D2x, F2x, G2x, 52x, H2x, 62x, J2x, L2x, 32x, DDx, M2x
46M0912	3876	6Gb Performance Optimized HBA	1	-
46C8988	A3MW	N2115 SAS/SATA HBA	1	-
Features on Demand upgrades (per server)				
81Y4542	A1X1	ServeRAID M1100 Series Zero Cache/RAID 5 Upgrade	1	-
81Y4544	A1X2	ServeRAID M5100 Series Zero Cache/RAID 5 Upgrade	1	-
81Y4546	A1X3	ServeRAID M5100 Series RAID 6 Upgrade	1†	-
90Y4273	A2MC	ServeRAID M5100 Series Performance Accelerator	1†	-
90Y4318	A2MD	ServeRAID M5100 Series SSD Caching Enabler	1†	-
Hardware upgrades (per controller)				
81Y4484	A1J3	ServeRAID M5100 Series 512MB Cache/RAID 5 Upgrade	1	DDx
81Y4487	A1J4	ServeRAID M5100 Series 512MB Flash/RAID 5 Upgrade	1	D2x, F2x
81Y4559	A1WY	ServeRAID M5100 Series 1GB Flash/RAID 5 Upgrade	1	G2x, H2x, J2x, L2x, 52x, 62x
47C8670	A4G6	ServeRAID M5100 Series 2GB Flash/RAID 5 Upgrade	1	-
81Y4508	A22E	ServeRAID M5100 Series Battery Kit	1*	DDx

* The ServeRAID M5100 Series Battery Kit (81Y4508) is only supported with ServeRAID M5100 Series 512MB Cache/RAID 5 Upgrade (81Y4484).

† This FoD upgrade requires a cache memory upgrade.

Table 8. RAID controllers and HBAs for internal storage (Part 2: 12 Gbps SAS / 6 Gbps SATA)

Part number	Feature code	Description	Maximum supported	Standard models where used
12 Gb Controllers				
46C9114	A45W	ServeRAID M1215 SAS/SATA Controller	1	-
46C9110	A3YZ	ServeRAID M5210 SAS/SATA Controller	1	-
00AE912	A5M0	N2225 SAS/SATA HBA	1	-
47C8675	A3YY	N2215 SAS/SATA HBA	1	-
Hardware upgrades (per controller)				
47C8656	A3Z0	ServeRAID M5200 Series 1GB Cache/RAID 5 Upgrade	1	-
47C8660	A3Z1	ServeRAID M5200 Series 1GB Flash/RAID 5 Upgrade	1	-
47C8664	A3Z2	ServeRAID M5200 Series 2GB Flash/RAID 5 Upgrade	1	-
47C8668	A3Z3	ServeRAID M5200 Series 4GB Flash/RAID 5 Upgrade	1	-
Feature on Demand upgrades (per server)				
00AE930	A5H5	ServeRAID M1200 Zero Cache/RAID 5 Upgrade	1	-
47C8708	A3Z6	ServeRAID M5200 Series Zero Cache/RAID 5 Upgrade	1	-
47C8706	A3Z5	ServeRAID M5200 Series RAID 6 Upgrade	1*	-
47C8710	A3Z7	ServeRAID M5200 Series Performance Accelerator	1*	-
47C8712	A3Z8	ServeRAID M5200 Series SSD Caching Enabler	1*	-

* Requires cache memory upgrade (47C8656, 47C8660, 47C8664, or 47C8668).

The ServeRAID H1110 adapter has the following specifications:

- Four internal 6 Gbps SAS/SATA ports
- One x4 mini-SAS internal connector (SFF-8087)
- Up to 6 Gbps throughput per port
- Based on LSI SAS2004 6 Gbps RAID on Chip (ROC) controller
- PCIe x4 Gen 3 host interface
- Supports RAID 0, 1, 1E, and 10
- Connects to up to four SAS or SATA drives

The ServeRAID M1115 SAS/SATA Controller has the following specifications:

- Eight internal 6 Gbps SAS/SATA ports
- Two x4 mini-SAS internal connectors (SFF-8087)
- Supports RAID levels 0, 1, and 10
- Supports RAID levels 5 and 50 with optional M1100 Series RAID 5 upgrades
- Up to 6 Gbps throughput per port
- PCIe x8 Gen 3 host interface
- Based on the LSI SAS2008 6 Gbps ROC controller

The ServeRAID M5110 SAS/SATA Controller has the following specifications:

- Eight internal 6 Gbps SAS/SATA ports
- Two x4 mini-SAS internal connectors (SFF-8087)
- Supports RAID levels 0, 1, and 10
- Supports RAID levels 5 and 50 with optional M5100 Series RAID 5 upgrades
- Supports RAID 6 and 60 with the optional M5100 Series RAID 6 Upgrade
- Supports 512 MB battery-backed cache or 512 MB, 1 GB, or 2 GB flash-backed cache
- Up to 6 Gbps throughput per port
- PCIe x8 Gen 3 host interface
- Based on the LSI SAS2208 6 Gbps ROC controller

The ServeRAID M5210 SAS/SATA Controller has the following specifications:

- Eight internal 12 Gbps SAS/SATA ports
- Two x4 HD mini-SAS internal connectors (SFF-8643)
- Supports connections to SAS/SATA drives and SAS Expanders
- Supports RAID levels 0, 1, and 10
- Supports RAID levels 5 and 50 with optional M5200 Series RAID 5 upgrades
- Supports RAID 6 and 60 with the optional M5200 Series RAID 6 Upgrade
- Supports 1 GB non-backed cache or 1 GB, 2 GB, or 4 GB flash-backed cache
- Up to 12 Gbps throughput per port
- PCIe 3.0 x8 host interface
- Based on the LSI SAS3108 12 Gbps ROC controller

The 6Gb Performance Optimized HBA has the following specifications:

- Eight internal 6 Gbps SAS/SATA ports
- Two x4 mini-SAS internal connectors (SFF-8087)
- Supports connections to SAS/SATA HDDs and SATA SSDs
- Optimized for SSD performance
- No RAID support
- Up to 6 Gbps throughput per port
- PCIe 2.0 x8 host interface
- Based on the LSI SAS2008 6 Gbps controller

The N2115 SAS/SATA HBA has the following specifications:

- Eight internal 6 Gbps SAS/SATA ports
- Two x4 mini-SAS internal connectors (SFF-8087)
- Supports connections to SAS/SATA HDDs and SATA SSDs
- Optimized for SSD performance
- No RAID support
- Up to 6 Gbps throughput per port
- PCIe 3.0 x8 host interface
- Based on the LSI SAS2308 6 Gbps controller

The N2215 SAS/SATA HBA has the following specifications:

- Eight internal 12 Gbps SAS/SATA ports
- Two x4 HD mini-SAS internal connectors (SFF-8643)
- Supports connections to SAS/SATA HDDs and SATA SSDs
- Optimized for SSD performance
- No RAID support
- Up to 12 Gbps throughput per port
- PCIe 3.0 x8 host interface
- Based on the LSI SAS3008 12 Gbps controller

For more information, see the list of Lenovo Press Product Guides in the RAID adapters category:

<https://lenovopress.com/servers/options/raid?rt=product-guide>

Internal drive options

The following table lists hard drive options for internal disk storage of the x3550 M4 server.

Table 9. Disk drive options for internal disk storage

Part number	Feature code	Description	Maximum supported
2.5-inch hot-swap HDDs - 6 Gbps SAS			
90Y8926	A2XB	146GB 15K 6Gbps SAS 2.5" SFF G2HS HDD	8
90Y8877	A2XC	300GB 10K 6Gbps SAS 2.5" SFF G2HS HDD	8
81Y9670	A283	300GB 15K 6Gbps SAS 2.5" G2HS HDD	8
90Y8872	A2XD	600GB 10K 6Gbps SAS 2.5" SFF G2HS HDD	8
00AJ300	A4VB	600GB 15K 6Gbps SAS 2.5" G2HS HDD	8
81Y9650	A282	900GB 10K 6Gbps SAS 2.5" SFF HS HDD	8
00AD075	A48S	1.2TB 10K 6Gbps SAS 2.5" G2HS HDD	8
00NA441	ASCD	1.8TB 10K 6Gbps SAS 2.5" G2HS 512e HDD	8
2.5-inch hot-swap HDDs - 6 Gbps NL SAS			
90Y8953	A2XE	500GB 7.2K 6Gbps NL SAS 2.5" SFF G2HS HDD	8
81Y9690	A1P3	1TB 7.2K 6Gbps NL SAS 2.5" SFF HS HDD	8
2.5-inch hot-swap HDDs - 6 Gbps NL SATA			
81Y9722	A1NX	250GB 7.2K 6Gbps NL SATA 2.5" SFF HS HDD	8
81Y9726	A1NZ	500GB 7.2K 6Gbps NL SATA 2.5" SFF HS HDD	8
81Y9730	A1AV	1TB 7.2K 6Gbps NL SATA 2.5" SFF HS HDD	8
2.5-inch hot-swap SEDs - 6 Gbps SAS			
90Y8913	A2XF	300GB 10K 6Gbps SAS 2.5" SFF G2HS SED	8
90Y8908	A3EF	600GB 10K 6Gbps SAS 2.5" SFF G2HS SED	8
81Y9662	A3EG	900GB 10K 6Gbps SAS 2.5" SFF G2HS SED	8
00AD085	A48T	1.2TB 10K 6Gbps SAS 2.5" G2HS SED	8
2.5-inch hot-swap SDDs - Enterprise 6 Gbps SAS			
49Y6129	A3EW	200GB SAS 2.5" MLC HS Enterprise SSD	8
49Y6134	A3EY	400GB SAS 2.5" MLC HS Enterprise SSD	8
49Y6139	A3F0	800GB SAS 2.5" MLC HS Enterprise SSD	8
49Y6195	A4GH	1.6TB SAS 2.5" MLC HS Enterprise SSD	8
2.5-inch hot-swap SDDs - Enterprise 6 Gbps SATA			
41Y8331	A4FL	S3700 200GB SATA 2.5" MLC HS Enterprise SSD	8
41Y8336	A4FN	S3700 400GB SATA 2.5" MLC HS Enterprise SSD	8
41Y8341	A4FQ	S3700 800GB SATA 2.5" MLC HS Enterprise SSD	8
2.5-inch hot-swap SDDs - Enterprise Entry/Value 6 Gbps SATA			
00YC365	AT8M	120GB Enterprise Entry SATA HS 2.5" SSD	8
00AJ355	A56Z	120GB SATA 2.5" MLC HS Enterprise Value SSD	8
00YC370	AT8N	240GB Enterprise Entry SATA HS 2.5" SSD	8
00AJ360	A570	240GB SATA 2.5" MLC HS Enterprise Value SSD	8
00FN298	AS0D	240GB SATA 2.5" MLC HS Entry SSD	8
00YC375	AT8P	480GB Enterprise Entry SATA HS 2.5" SSD	8
00AJ365	A571	480GB SATA 2.5" MLC HS Enterprise Value SSD	8

Part number	Feature code	Description	Maximum supported
00FN327	AS0E	480GB SATA 2.5" MLC HS Entry SSD	8
00AJ370	A572	800GB SATA 2.5" MLC HS Enterprise Value SSD	8
00YC380	AT8Q	960GB Enterprise Entry SATA HS 2.5" SSD	8
00AJ000	A4KM	S3500 120GB SATA 2.5" MLC HS Enterprise Value SSD	8
00AJ005	A4KN	S3500 240GB SATA 2.5" MLC HS Enterprise Value SSD	8
00AJ010	A4KP	S3500 480GB SATA 2.5" MLC HS Enterprise Value SSD	8
00AJ015	A4KQ	S3500 800GB SATA 2.5" MLC HS Enterprise Value SSD	8
00FN268	A5U4	S3500 1.6TB SATA 2.5" MLC HS Enterprise Value SSD	8
3.5-inch hot-swap HDDs - 6 Gbps SAS			
49Y6092	A3DV	300GB 15K 6Gbps SAS 3.5" G2HS HDD	3
49Y6102	A3DX	600GB 15K 6Gbps SAS 3.5" G2HS HDD	3
3.5-inch hot-swap HDDs - 6 Gbps NL SAS			
90Y8567	A26M	1TB 7.2K 6Gbps NL SAS 3.5" G2HS HDD	3
90Y8572	A2U0	2TB 7.2K 6Gbps NL SAS 3.5" G2HS HDD	3
90Y8577	A2R2	3TB 7.2K 6Gbps NL SAS 3.5" G2HS HDD	3
49Y6210	A4AF	4TB 7.2K 6Gbps NL SAS 3.5" G2HS HDD	3
00ML213	AS78	6TB 7.2K 6Gbps NL SAS 3.5" G2HS 512e HDD	3
3.5-inch hot-swap HDDs - 6 Gbps NL SATA			
81Y9786	A22Y	500GB 7.2K 6Gbps NL SATA 3.5" G2HS HDD	3
81Y9790	A22P	1TB 7.2K 6Gbps NL SATA 3.5" G2HS HDD	3
81Y9794	A22T	2TB 7.2K 6Gbps NL SATA 3.5" G2HS HDD	3
00FN113	A5VD	2TB 7.2K 6Gbps NL SATA 3.5" G2HS 512e HDD	3
81Y9798	A22S	3TB 7.2K 6Gbps NL SATA 3.5" G2HS HDD	3
49Y6002	A3W9	4TB 7.2K 6Gbps NL SATA 3.5" G2HS HDD	3
00FN143	A5VH	4TB 7.2K 6Gbps NL SATA 3.5" G2HS 512e HDD	3
00FN173	A5VM	6TB 7.2K 6Gbps NL SATA 3.5" G2HS 512e HDD	3
3.5-inch hot-swap SEDs - 6 Gbps NL SATA			
00W1543	A4AJ	4TB 7.2K 6Gbps NL SAS 3.5" G2HS SED	3
3.5-inch simple-swap HDDs - 6 Gbps NL SATA			
81Y9802	A22U	500GB 7.2K 6Gbps NL SATA 3.5" G2SS HDD	3
81Y9806	A22X	1TB 7.2K 6Gbps NL SATA 3.5" G2SS HDD	3
81Y9810	A22W	2TB 7.2K 6Gbps NL SATA 3.5" G2SS HDD	3

Internal backup units

The server does not support internal tape drive options or other internal backup units. However, it can be attached to the external tape drives using SAS or Fibre Channel connectivity (see Table 26).

Optical drives

The server supports the optical drive options listed in the following table. Server models with 3.5" HDDs do not support internal optical drive; they provide a third USB port on the front for an external optical drive.

Table 10. Optical drives

Part number	Feature code	Description	Maximum supported	Standard models where used
46M0901	4161	UltraSlim Enhanced SATA DVD-ROM	1	-
46M0902	4163	UltraSlim Enhanced SATA Multi-Burner	1	-

UltraSlim Enhanced SATA DVD-ROM (part number 46M0901) supports the following media and speeds for reading:

- CD-ROM 24X
- CD-DA (DAE) 20X
- CD-R 24X
- CD-RW 24X
- DVD-ROM (single layer) 8X
- DVD-ROM (dual layer) 8X
- DVD-R (4.7 GB) 6X
- DVD-R DL 4X
- DVD+R 6X
- DVD+R DL 4X
- DVD-RW (4.7 GB) 4X
- DVD+RW 4X
- DVD-RAM (4.7/9.4 GB) 4X

UltraSlim Enhanced SATA Multi-Burner (46M0902) supports the same media and speeds for reading as DVD-ROM (46M0901). This drive also supports the following media and speeds for writing:

- CD-R 24X
- CD-RW 4X
- High Speed CD-RW 10X
- Ultra Speed CD-RW 16X
- Ultra Speed Plus CD-RW 16X
- DVD-R 8X
- DVD-R DL 6X
- DVD+R 8X
- DVD+R DL 6X
- DVD-RW 6X
- DVD+RW 8X
- DVD-RAM 5X

I/O expansion options

The server supports two PCI slots with different riser cards installed into two riser sockets on the system planar (one riser socket supports the installation of one riser card). The slot form factors are as follows:

- Slot 1: PCIe x16; low profile, half-length
- Slot 2: PCIe x16, PCIe x8, or PCI-X; full-height, half-length (PCIe x16 slot requires second processor)

Riser 1 supplies slot 1, and riser 2 supplies slot 2. All standard models except for model DDx have two riser cards installed that provide one PCIe x16 Gen 3 slot and one PCIe x8 Gen 3 slot (features A1HJ and A1HK). Model DDx has two PCIe x16 slots (A1HJ and A1HL).

You can replace the second riser card with one of the following (or configure one of these riser cards instead of the second riser card using special bid or CTO), provided a second processor is also installed:

- A riser with one PCIe x16 Gen 3 slot (69Y5671, feature A1HL)
- A riser with one PCIe x8 Gen 3 slot (69Y5670, feature A1HK)
- A riser with one PCI-X 64 bit/133 MHz slot (69Y5669, feature A1HM)

The following table lists the PCI riser card options.

Table 11. PCI riser card options

Part number	Feature code	Description	Maximum supported	Models where used
94Y7585	A1HJ	x3550 M4 PCIe Riser Card 1 (1 x16 LP Slot)	1	All models
69Y5670	A1HK	x3550 M4 PCIe Gen-III Riser Card 2 (1 x8 FH/HL Slot)	1	All models except DDx
69Y5671	A1HL	x3550 M4 PCIe Gen-III Riser Card 2 (1 x16 FH/HL Slot)	1	DDx
69Y5669	A1HM	x3550 M4 PCI-X Riser Card 2 (1 PCIX FH/HL Slot)	1	-

The x3550 M4 Thermal Solution Kit, 00Y7117 contains two 40mm fans which provides the fifth and sixth system fans needed for these options when only one processor is installed:

- All supported PCIe SSD adapters
- QLogic Dual Port 10GbE SFP+ Embedded VFA
- QLogic 8200 Dual Port 10GbE SFP+ VFA
- ServeRAID M5120 SAS/SATA Controller
- Solarflare SFN5162F MR Dual Port 10GbE SFP+ Adapter

The Thermal Solution Kit is not needed if two processors are installed, since the second processor includes these fans.

Table 12. Thermal Solution Kit

Part number	Feature code	Description	Maximum supported
00Y7117	A47L*	x3550 M4 Thermal Solution Kit (contains two fans)	1

* For CTO orders, quantity two of feature code A40L, x3550 M4 Addl Fan for High Performance Adapters will be substituted.

Network adapters

The x3550 M4 supports four integrated Gigabit Ethernet ports.

Integrated NICs have the following features:

- An Intel I350AM4 chip
- Four GbE ports
- TCP Offload Engine (TOE) support
- Wake on LAN support
- 802.1Q VLAN tagging support
- IPv6 support
- NIC Teaming (load balancing and failover)

Optionally, two 10 Gb Ethernet ports can be added by installing the a dual-port 10 Gb Ethernet mezzanine card as listed in the following table. Mezzanine cards use a dedicated connector on the system board and do not consume a PCI expansion slot.

The following table lists additional supported network adapters.

Table 13. Network adapters

Part number	Feature code	Description	Maximum supported
10 Gb Ethernet Mezzanine cards (does not consume a PCI expansion slot)			
44T1360	A4YQ	Broadcom NetXtreme 2x10GbE SFP+ Mezz Adapter	1*
49Y7980	A3JS	Intel X520 Dual Port 10GbE SFP+ Embedded Adapter	1*
49Y7990	A3JT	Intel X540 Dual Port 10GBase-T Embedded Adapter	1
90Y6454	A22H	QLogic Dual Port 10GbE SFP+ Embedded VFA	1*†
90Y5179	A2TF	QLogic Embedded VFA FCoE/iSCSI License (FoD upgrade for 90Y6454)	1
InfiniBand Mezzanine cards (does not consume a PCI expansion slot)			
00D4143	A36R	Dual Port FDR Embedded Adapter	1*
40 Gb Ethernet / FDR InfiniBand			
00D9550	A3PN	Mellanox ConnectX-3 FDR VPI IB/E Adapter	2*
10 Gb Ethernet			
44T1370	A5GZ	Broadcom NetXtreme 2x10GbE BaseT Adapter	2
94Y5180	A4Z6	Broadcom NetXtreme Dual Port 10GbE SFP+ Adapter	2*
00JY820	A5UT	Emulex VFA5 2x10 GbE SFP+ PCIe Adapter	1*
00JY830	A5UU	Emulex VFA5 2x10 GbE SFP+ Adapter and FCoE/iSCSI SW	1*
None**	AS3M	Emulex VFA5 2x10 GbE SFP+ Integrated Adapter	1*
00JY824	A5UV	Emulex VFA5 FCoE/iSCSI SW for PCIe Adapter (FoD license for 00JY820 or feature AS3M; included with 00JY830)	1
49Y7960	A2EC	Intel X520-DA2 Dual Port 10GbE SFP+ Adapter	2*
49Y7970	A2ED	Intel X540-T2 Dual Port 10GBase-T Adapter	2
81Y3520	AS73	Intel X710 2x10GbE SFP+ Adapter	2*
81Y9990	A1M4	Mellanox ConnectX-2 Dual Port 10GbE Adapter	2*
00D9690	A3PM	Mellanox ConnectX-3 10GbE Adapter	2*
90Y4600	A3MR	QLogic 8200 Dual Port 10GbE SFP+ VFA	2*†
00Y5624	A3MT	QLogic 8200 VFA FCoE/iSCSI License (FoD license for 90Y4600)	2
47C9952	A47H	Solarflare SFN5162F MR Dual Port 10GbE SFP+ Adapter	2*
47C9977	A522	Solarflare SFN7122F 2x10GbE SFP+ Flareon Ultra	2*
Gigabit Ethernet			
00AG500	A56K	Intel I350-F1 1xGbE Fiber Adapter	2
00AG510	A56L	Intel I350-T2 2xGbE BaseT Adapter	2
00AG520	A56M	Intel I350-T4 4xGbE BaseT Adapter	2
42C1780	2995	Broadcom NetXtreme 2xGbE BaseT Adapter	2
49Y4230	5767	Intel Ethernet Dual Port Server Adapter I340-T2	2
49Y4240	5768	Intel Ethernet Quad Port Server Adapter I340-T4	2
90Y9352	A2V3	Broadcom NetXtreme I Quad Port GbE Adapter	2
90Y9370	A2V4	Broadcom NetXtreme I Dual Port GbE Adapter	2

* SFP+ and QSFP+ based adapters require supported transceivers or DAC cables that must be purchased separately.
† The QLogic Dual Port 10GbE SFP+ Embedded VFA and QLogic 8200 Dual Port 10GbE SFP+ VFA both require the x3550 M4 Thermal Solution Kit, 00Y7117 or the second processor (with additional system fans).

** CTO only.

For more information, see the list of Lenovo Press Product Guides in the Networking adapters category:
<https://lenovopress.com/servers/options/ethernet?rt=product-guide>

Storage host bus adapters

The following table lists storage HBAs supported by the x3550 M4 server.

Table 14. Storage adapters

Part number	Feature code	Description	Maximum supported
Fibre Channel - 16 Gb			
81Y1662	A2W6	Emulex 16Gb FC Dual-port HBA	2
81Y1655	A2W5	Emulex 16Gb FC Single-port HBA	2
00Y3337	A3KW	QLogic 16Gb FC Single-port HBA	2
00Y3341	A3KX	QLogic 16Gb FC Dual-port HBA	2
Fibre Channel - 8 Gb			
42D0485	3580	Emulex 8Gb FC Single-port HBA	2
42D0494	3581	Emulex 8Gb FC Dual-port HBA	2
42D0501	3578	QLogic 8Gb FC Single-port HBA	2
42D0510	3579	QLogic 8Gb FC Dual-port HBA	2
SAS			
46M0907	5982	6Gb SAS HBA	2
46C9010	A3MV	N2125 SAS/SATA HBA	2
00AE912	A5M0	N2225 SAS/SATA HBA	2

For more information, see the list of Lenovo Press Product Guides in the Host bus adapters category:
<https://lenovopress.com/servers/options/hba?rt=product-guide>

PCIe SSD adapters

The server supports the High IOPS SSD adapters listed in the following table.

Table 15. SSD adapters

Part number	Feature code	Description	Maximum supported
Enterprise			
00AE995	ARYP	1000GB Enterprise io3 Flash Adapter	1
00AE998	ARYQ	1300GB Enterprise io3 Flash Adapter	1
00JY001	ARYR	2600GB Enterprise io3 Flash Adapter	1
00JY004	ARYS	5200GB Enterprise io3 Flash Adapter	1*
Enterprise Value			
00AE983	ARYK	1250GB Enterprise Value io3 Flash Adapter	1
00AE986	ARYL	1600GB Enterprise Value io3 Flash Adapter	1
00AE989	ARYM	3200GB Enterprise Value io3 Flash Adapter	1
00AE992	ARYN	6400GB Enterprise Value io3 Flash Adapter	1*

* The 5200GB and 6400GB io3 Flash Adapters cannot be factory installed; they are supported as field-installable options only. The server cannot be shipped with these adapters installed.

For details about these adapters, see the Lenovo Press Product Guides in the PCIe SSD Adapters category, found at the following address:

<https://lenovopress.com/servers/options/ssdadapter?rt=product-guide>

GPU adapters

The server supports a graphics processing unit (GPU) provided the x16 riser card (69Y5671, feature A1HL) is installed. The server provides up to 225W of external power to each GPU. The following table lists the supported GPUs.

Table 16. GPU adapters

Part number	Feature code	Description	Maximum supported
None*	A3WH	NVIDIA Quadro K600	1

* These GPU adapters are available via Special Bid or CTO only.

If the NVIDIA Quadro K600 is installed, the maximum memory that can be installed is 1 TB.

Power supplies

The server supports up to two redundant power supplies, providing N+1 redundancy. Standard models come with one or two power supplies (model dependent). The following table lists the power supplies. An AC power supply ships standard with one 2.8 m C13 - C14 power cord.

Table 17. Power supplies

Part number	Feature code	Description	Maximum supported	Standard models where used
94Y6668	A1H6	System x 550W High Efficiency Platinum AC Power Supply	2	All other models
94Y6669	A1H5	System x 750W High Efficiency Platinum AC Power Supply	2	L2x, 32x, M2x
94Y7631	A39N	System x 750W High Efficiency -48 V DC Power Supply	2	-

General power supply rules are as follows:

- Minimum of 1 and maximum of 2 power supplies per system.
- If 2 are installed, power supplies must be identical.

Important: It is highly recommended to validate server configuration for specific power requirements using the latest version of the System x Power Configurator:

<https://www.ibm.com/support/entry/portal/docdisplay?lnvo=pwrconf>

This will ensure that the right power supply is chosen for optimal performance.

Integrated virtualization

The server supports VMware ESXi installed on a USB memory key. The key is installed in a USB socket inside the server. The following table lists the virtualization options.

Table 18. Virtualization options

Part number	Feature code	Description	Maximum supported
41Y8298	A2G0	Blank USB Memory Key for VMware ESXi Downloads	1
41Y8382	A4WZ	USB Memory Key for VMware ESXi 5.1 Update 1	1

Systems management

The server contains Integrated Management Module II (IMM2), which provides advanced service-processor control, monitoring, and an alerting function. If an environmental condition exceeds a threshold or if a system component fails, the IMM lights LEDs to help you diagnose the problem, records the error in the event log, and alerts you to the problem. Optionally, the IMM also provides a virtual presence capability for remote server management capabilities.

The IMM provides remote server management through industry-standard interfaces:

- Intelligent Platform Management Interface (IPMI) Version 2.0
- Simple Network Management Protocol (SNMP) Version 3
- Common Information Model (CIM)
- Web browser

The optional Integrated Management Module Advanced Upgrade is required to enable the remote presence and blue-screen capture features. The remote presence feature provides the following functions:

- Remotely viewing video with graphics resolutions up to 1600x1200 at 75 Hz with up to 23 bits per pixel, regardless of the system state
- Remotely accessing the server using the keyboard and mouse from a remote client
- Mapping the CD or DVD drive, diskette drive, and USB flash drive on a remote client, and mapping ISO and diskette image files as virtual drives that are available for use by the server
- Uploading a diskette image to the IMM memory and mapping it to the server as a virtual drive

The blue-screen capture feature captures the video display contents before the IMM restarts the server when the IMM detects an operating system hang condition. A system administrator can use the blue-screen capture to assist in determining the cause of the hang condition. The following table lists the remote management option.

Table 19. Remote management option

Part number	Feature code	Description	Maximum quantity supported
90Y3901	A1ML	Integrated Management Module Advanced Upgrade	1

All standard models ship with a pop-out light path diagnostics panel on the front of the server (See [Figure 2](#)). Configure-to-order (CTO) customers may elect to deselect this feature and instead have a basic light path diagnostics panel on the front of the server. The following table shows the two light path diagnostics features.

Table 20. Light path diagnostics options

Part number	Feature code	Description	Maximum supported	Models where used
None*	A1LF	System x Lightpath Kit	1	-
00Y7676	A2U6	System x Advanced Lightpath Kit	1	All models

* CTO only

Operating systems

The server supports the following operating systems:

- Microsoft Windows Server 2012 R2
- Microsoft Windows Server 2012
- Microsoft Windows Server 2008 R2
- Microsoft Windows Server 2008, Datacenter x64 Edition
- Microsoft Windows Server 2008, Datacenter x86 Edition
- Microsoft Windows Server 2008, Enterprise x64 Edition
- Microsoft Windows Server 2008, Enterprise x86 Edition
- Microsoft Windows Server 2008, Standard x64 Edition
- Microsoft Windows Server 2008, Standard x86 Edition
- Microsoft Windows Server 2008, Web x64 Edition
- Microsoft Windows Server 2008, Web x86 Edition
- Microsoft Windows Small Business Server 2008 Premium Edition
- Microsoft Windows Small Business Server 2008 Standard Edition
- Red Hat Enterprise Linux 5 Server with Xen x64 Edition
- Red Hat Enterprise Linux 5 Server x64 Edition
- Red Hat Enterprise Linux 6 Server Edition
- Red Hat Enterprise Linux 6 Server x64 Edition
- Red Hat Enterprise Linux 7
- SUSE LINUX Enterprise Server 10 for AMD64/EM64T
- SUSE LINUX Enterprise Server 11 for AMD64/EM64T
- SUSE LINUX Enterprise Server 11 for x86
- SUSE LINUX Enterprise Server 11 with Xen for AMD64/EM64T
- SUSE LINUX Enterprise Server 12
- SUSE LINUX Enterprise Server 12 with Xen
- VMware ESX 4.1
- VMware ESXi 4.1
- VMware vSphere (ESXi) 5.0
- VMware vSphere (ESXi) 5.1
- VMware vSphere (ESXi) 5.5

See the ServerProven® website for the latest information about the specific versions and service levels supported and any other prerequisites:

www.lenovo.com/us/en/serverproven/

Physical and electrical specifications

Dimensions and weight:

- Height: 43 mm (1.7 in)
- Width: 429 mm (16.9 in)
- Depth: 734 mm (28.9 in)
- Weight:
 - Minimum configuration: 12.7 kg (28 lb)
 - Maximum configuration: 15.9 kg (35.1 lb)

Supported environment:

- Air temperature
 - Server on: 5 °C to 40 °C (41 °F to 104 °F); altitude: 0 to 950 m (3,117 ft); decrease the maximum system temperature by 1 °C for every 175-m increase in altitude.
 - Server off: 5 °C to 45 °C (41 °F to 113 °F)
 - Maximum altitude: 3,050 m (10,000 ft), 5 °C to 28 °C (41 °F to 82 °F)
 - Shipment: -40 °C to +60 °C (-40 °F to 140 °F)

- Specific microprocessors:
 - Microprocessor Intel Xeon E5-2690, 135 W:
 - Temperature: 10 °C to 27 °C (50 °F to 80.6 °F)
 - Altitude: 0 to 304.8 m (1,000 ft)
 - Microprocessor models with 115 W and 130 W:
 - Temperature: 10 °C to 35 °C (50 °F to 95 °F)
 - Altitude: 0 to 914.4 m (3,000 ft)
- Humidity
 - Server on: 8% to 85%, maximum dew point 24 °C, maximum rate of change 5 °C/hr
 - Server off: 8% to 85%, maximum dew point 27 °C
- Design to ASHRAE Class A3, ambient of 36 °C to 40 °C (96.8 °F to 104 °F), with relaxed support:
 - Supports cloud like workload with no performance degradation acceptable (Turbo-Off).
 - Under no circumstance can any combination of worst case workload and configuration result in system shutdown or design exposure at 40 °C.
- Electrical
 - Models with 750 W power supplies:
 - 100 to 127 (nominal) V ac; 50 Hz or 60 Hz; 8.9 A
 - 200 to 240 (nominal) V ac; 50 Hz or 60 Hz; 4.5 A
 - Input kilovolt-amperes (kVA) (approximately):
 - Minimum configuration: 0.14 kVA
 - Maximum configuration: 0.9 kVA
 - Models with 550 W power supplies:
 - 100 to 127 (nominal) V ac; 50 Hz or 60 Hz; 6.5 A
 - 200 to 240 (nominal) V ac; 50 Hz or 60 Hz; 3.3 A
 - Input kilovolt-amperes (kVA) (approximately):
 - Minimum configuration: 0.14 kVA
 - Maximum configuration: 0.66 kVA
- BTU output
 - Minimum configuration: 461 Btu/hr (135 watts)
 - Maximum configuration: 2900 Btu/hr (850 watts)
- Noise level
 - 6.5 bels (operating)
 - 6.3 bels (idle)

Warranty options

The System x3550 M4 has a three-year warranty with 24x7 standard call center support and 9x5 Next Business Day onsite coverage. Also available are Lenovo Services warranty maintenance upgrades and post-warranty maintenance agreements, with a well-defined scope of services, including service hours, response time, term of service, and service agreement terms and conditions.

Lenovo warranty service upgrade offerings are country-specific. Not all warranty service upgrades are available in every country. For more information about Lenovo warranty service upgrade offerings that are available in your country, visit the Lenovo Services website:

<https://www-304.ibm.com/sales/gss/download/spst/servicepac>

The following table explains warranty service definitions in more detail.

Table 21. Warranty service definitions

Term	Description
On-site service	A service technician will arrive at the client's location for equipment service.
24x7x2 hour	A service technician is scheduled to arrive at the client's location within two hours after remote problem determination is completed. Lenovo provides service around the clock, every day, including Lenovo holidays.
24x7x4 hour	A service technician is scheduled to arrive at the client's location within four hours after remote problem determination is completed. Lenovo provides service around the clock, every day, including Lenovo holidays.
9x5x4 hour	A service technician is scheduled to arrive at the client's location within four business hours after remote problem determination is completed. Lenovo provides service 8:00 am - 5:00 pm in the client's local time zone, Monday-Friday, excluding Lenovo holidays. For example, if a customer reports an incident at 3:00 pm on Friday, the technician will arrive by 10:00 am the following Monday.
9x5 next business day	A service technician is scheduled to arrive at the client's location on the business day after remote problem determination is completed. Lenovo provides service 8:00 am - 5:00 pm in the client's local time zone, Monday - Friday, excluding Lenovo holidays. Calls received after 4:00 pm local time require an extra business day for service dispatch. Next business day service is not guaranteed.
Committed Repair	Problems receive priority handling so that repairs are completed within the committed time of 6, 8, or 24 hours. Lenovo provides service 24 hours/day, every day, including Lenovo holidays.

The following Lenovo warranty service upgrades are available:

- Warranty and maintenance service upgrades:
 - Three, four, or five years of 9x5 or 24x7 service coverage
 - Onsite response from next business day to 2 or 4 hours
 - Committed repair service
 - Warranty extension of up to 5 years
 - Post warranty extensions
- Committed Repair Service

Committed Repair Services enhances the level of Warranty Service Upgrade or Post Warranty/Maintenance Service offering associated with the selected systems. Offerings vary and are available in select countries.

 - Priority handling to meet defined time frames to restore the failing machine to good working condition
 - Committed repair service levels are measured within the following coverage hours:
 - 24x7x6: Service performed 24 hours per day, 7 days per week, within 6 hours
 - 24x7x8: Service performed 24 hours per day, 7 days per week, within 8 hours
 - 24x7x24: Service performed 24 hours per day, 7 days per week, within 24 hours
- Hard Drive Retention

Lenovo's Hard Drive Retention service is a multi-drive hard drive retention offering that ensures your data is always under your control, regardless of the number of hard drives that are installed in your Lenovo server. In the unlikely event of a hard drive failure, you retain possession of your hard drive while Lenovo replaces the failed drive part. Your data stays safely on your premises, in your hands. The Hard Drive Retention service can be purchased in convenient bundles with our warranty upgrades and extensions.

- **Microcode Support**
Keeping microcode current helps prevent hardware failures and security exposure. There are two levels of service: analysis of the installed base and analysis and update where required. Offerings vary by country and can be bundled with other warranty upgrades and extensions.
- **Remote Technical Support Services (RTS)**
RTS provides comprehensive technical call center support for covered servers, storage, operating systems, and applications. Providing a single source for support of hardware and software issues, RTS can reduce problem resolution time, decreasing the cost to address technical problems and increasing uptime. Offerings are available for Windows, Linux, IBM Systems Director, VMware, Microsoft business applications, and Lenovo System x storage devices, and IBM OEM storage devices.

Regulatory compliance

The server conforms to the following standards:

- Energy Star 2.0
- FCC - Verified to comply with Part 15 of the FCC Rules, Class A
- Canada ICES-003, issue 4, Class A
- UL/IEC 60950-1
- CSA C22.2 No. 60950-1
- NOM-019
- Argentina IEC60950-1
- Japan VCCI, Class A
- Australia/New Zealand AS/NZS CISPR 22, Class A
- IEC 60950-1(CB Certificate and CB Test Report)
- China CCC (GB4943), GB9254 Class A, GB17625.1
- Taiwan BSMI CNS13438, Class A; CNS14336-1
- Korea KN22, Class A; KN24
- Russia/GOST ME01, IEC-60950-1, GOST R 51318.22, GOST R 51318.24, GOST R 51317.3.2, GOST R 51317.3.3
- IEC 60950-1 (CB Certificate and CB Test Report)
- CE Mark (EN55022 Class A, EN60950-1, EN55024, EN61000-3-2, EN61000-3-3)
- CISPR 22, Class A
- TUV-GS (EN60950-1 /IEC60950-1,EK1-ITB2000)
- RoHS (Directive 2011/65/E)

External disk storage expansion

The server supports attachment to external storage expansion enclosures, such as the EXP2500 series, by using the ServeRAID M5120 SAS/SATA Controller.

Table 22. RAID controllers and options for external disk storage expansion

Part number	Feature code	Description	Maximum supported	Standard models where used
81Y4478**	A1WX	ServeRAID M5120 SAS/SATA Controller	2**	-
Hardware upgrades for the M5120 (per controller)				
81Y4508	A22E	ServeRAID M5100 Series Battery Kit	1*	-
81Y4484	A1J3	ServeRAID M5100 Series 512MB Cache/RAID 5 Upgrade	1	-
81Y4487	A1J4	ServeRAID M5100 Series 512MB Flash/RAID 5 Upgrade	1	-
81Y4559	A1WY	ServeRAID M5100 Series 1GB Flash/RAID 5 Upgrade	1	-
47C8670	A4G6	ServeRAID M5100 Series 2GB Flash/RAID 5 Upgrade	1	-
Feature on Demand upgrades for the M5120 (per server)				
81Y4544	A1X2	ServeRAID M5100 Series Zero Cache/RAID 5 Upgrade	1	-
90Y4318	A2MD	ServeRAID M5100 Series SSD Caching Enabler	1†	-
90Y4273	A2MC	ServeRAID M5100 Series SSD Performance Key	1†	-
81Y4546	A1X3	ServeRAID M5100 Series RAID 6 Upgrade	1†	-

* The ServeRAID M5100 Series Battery Kit (81Y4508) is only supported with ServeRAID M5100 Series 512MB Cache/RAID 5 Upgrade (81Y4484).

† This FoD upgrade requires a cache memory upgrade.

** The ServeRAID M5120 SAS/SATA Controller requires the x3550 M4 Thermal Solution Kit, 00Y7117 or the second processor (with additional system fans).

The ServeRAID M5120 SAS/SATA Controller has the following specifications:

- Eight external 6 Gbps SAS/SATA ports
- Two external x4 mini-SAS connectors (SFF-8088)
- Supports RAID levels 0, 1, and 10
- Supports RAID levels 5 and 50 with optional M5100 Series RAID 5 upgrades
- Supports RAID 6 and 60 with the optional M5100 Series RAID 6 Upgrade
- Supports 512 MB battery-backed cache or 512 MB, 1 GB, or 2 GB flash-backed cache
- Up to 6 Gbps throughput per port
- PCIe x8 Gen 3 host interface
- Based on the LSI SAS2208 6 Gbps ROC controller
- Supports connectivity to the EXP2512 and EXP2524 storage expansion enclosures

For more information, see the Lenovo Press Product Guide *ServeRAID M5120 SAS/SATA Controller*: <http://lenovopress.com/tips0858>

The controllers support connectivity to the external expansion enclosures listed in the following table. Up to nine expansion enclosures can be daisy-chained per one external controller port. For better performance, distribute expansion enclosures evenly across both ports of a controller.

Table 23. External expansion enclosures

Part number	Description	Maximum quantity supported per one controller
610012X	EXP2512 Storage Enclosure	17
610024X	EXP2524 Storage Enclosure	9

The external SAS cables listed in the following table support connectivity between external expansion enclosures and the controller.

Table 24. External SAS cables for external storage expansion enclosures

Part number	Description	Maximum quantity supported per one enclosure
ServeRAID M5120 - Server to Expansion enclosure connectivity (Mini-SAS x4 to Mini-SAS x4)		
00WC017	1 m SAS Cable	1
00WC018	3 m SAS Cable	1
Expansion enclosure to Expansion enclosure connectivity (Mini-SAS x4 to Mini-SAS x4)		
00WC017	1 m SAS Cable	1
00WC018	3 m SAS Cable	1

The following table lists the drives supported by EXP2512 external expansion enclosures.

Table 25. Drive options for EXP2512 external expansion enclosures

Part number	Description	Maximum quantity supported per one enclosure
3.5" NL SAS HS HDDs		
00NC555	2TB 7,200 rpm 6Gb SAS NL 3.5" HDD	12
00NC557	3TB 7,200 rpm 6Gb SAS NL 3.5" HDD	12
00NC559	4TB 7,200 rpm 6Gb SAS NL 3.5" HDD	12

The following table lists the hard disk drives supported by EXP2524 external expansion enclosures.

Table 26. Drive options for EXP2524 external expansion enclosures

Part number	Description	Maximum quantity supported per one enclosure
2.5" NL SAS HS HDDs		
00NC571	1TB 7,200 rpm 6Gb SAS NL 2.5" HDD	24
2.5" SAS HS HDDs		
00NC561	146GB 15,000 rpm 6Gb SAS 2.5" HDD	24
00NC563	300GB 15,000 rpm 6Gb SAS 2.5" HDD	24
00NC565	600GB 10,000 rpm 6Gb SAS 2.5" HDD	24
00NC567	900GB 10,000 rpm 6Gb SAS 2.5" HDD	24
00NC569	1.2TB 10,000 rpm 6Gb SAS 2.5" HDD	24
2.5" SAS HS SSDs		
00NC573	200GB 6Gb SAS 2.5" SSD	24
00NC575	400GB 6Gb SAS 2.5" SSD	24

External disk storage systems

The following table lists the external storage systems that are offered by Lenovo that can be used in x3550 M4 solutions.

Table 27. External disk storage systems

Part number	Description
Lenovo Storage S2200	
64112B1	Lenovo Storage S2200 LFF Chassis SAS Single Controller, Rack Kit, 9x5NBD
64112B2	Lenovo Storage S2200 LFF Chassis SAS Dual Controller, Rack Kit, 9x5NBD
64114B1	Lenovo Storage S2200 LFF Chassis FC/iSCSI Single Controller, Rack Kit, 9x5NBD
64114B2	Lenovo Storage S2200 LFF Chassis FC/iSCSI Dual Controller, Rack Kit, 9x5NBD
64112B3	Lenovo Storage S2200 SFF Chassis SAS Single Controller, Rack Kit, 9x5NBD
64112B4	Lenovo Storage S2200 SFF Chassis SAS Dual Controller, Rack Kit, 9x5NBD
64114B3	Lenovo Storage S2200 SFF Chassis FC/iSCSI Single Controller, Rack Kit, 9x5NBD
64114B4	Lenovo Storage S2200 SFF Chassis FC/iSCSI Dual Controller, Rack Kit, 9x5NBD
Lenovo Storage S3200	
64113B1	Lenovo Storage S3200 LFF Chassis SAS Single Controller, Rack Kit, 9x5NBD
64113B2	Lenovo Storage S3200 LFF Chassis SAS Dual Controller, Rack Kit, 9x5NBD
64116B1	Lenovo Storage S3200 LFF Chassis FC/iSCSI Single Controller, Rack Kit, 9x5NBD
64116B2	Lenovo Storage S3200 LFF Chassis FC/iSCSI Dual Controller, Rack Kit, 9x5NBD
64113B3	Lenovo Storage S3200 SFF Chassis SAS Single Controller, Rack Kit, 9x5NBD
64113B4	Lenovo Storage S3200 SFF Chassis SAS Dual Controller, Rack Kit, 9x5NBD
64116B3	Lenovo Storage S3200 SFF Chassis FC/iSCSI Single Controller, Rack Kit, 9x5NBD
64116B4	Lenovo Storage S3200 SFF Chassis FC/iSCSI Dual Controller, Rack Kit, 9x5NBD
IBM Storwize	
6096CU2	IBM Storwize V3500 3.5-inch Dual Control Storage Controller Unit
6096CU3	IBM Storwize V3500 2.5-inch Dual Control Storage Controller Unit
6099L2C	IBM Storwize V3700 3.5-inch Storage Controller Unit
6099S2C	IBM Storwize V3700 2.5-inch Storage Controller Unit
6099T2C	IBM Storwize V3700 2.5-inch DC Storage Controller Unit
6194L2C	IBM Storwize V5000 LFF Control Enclosure
6194S2C	IBM Storwize V5000 SFF Control Enclosure
6195SC5	IBM Storwize V7000 2.5-inch Storage Controller Unit

For more information, see the list of Product Guides in the following categories:

- Lenovo Storage
<https://lenovopress.com/storage/san/lenovo>
- IBM Storage
<https://lenovopress.com/storage/san/ibm>

External backup units

The following table lists the external backup options that are offered by Lenovo that can be used in x3550 M4 solutions.

Table 28. External backup options

Part number	Description
External tape enclosures	
61901UX	IBM Multimedia Backup Enclosure
Backup drives for IBM Multimedia Backup Enclosure	
00NV402	6190 HH LTO5 SAS Tape Drive
00NV404	6190 HH LTO6 SAS Tape Drive
00NV406	6190 RDX 3.0 Dock/320GB Cartridge Bundle
00NV407	6190 RDX 3.0 Dock/500GB Cartridge Bundle
00NV408	6190 RDX 3.0 Dock/1.0TB Cartridge Bundle
00NV455	6190 RDX 3.0 Dock/2.0TB Cartridge Bundle
External backup units	
362532Y	RDX External USB 3.0 Dock with 320GB Cartridge
362550Y	RDX External USB 3.0 Dock with 500GB Cartridge
36251TY	RDX External USB 3.0 Dock with 1TB Cartridge
6160S6X	IBM TS2360 Tape Drive Model S63
6160S6E	IBM TS2260 Tape Drive Model H6S
6160S5E	IBM TS2250 Tape Drive Model H5S
6171S4R	IBM TS2900 Tape Autoloader w/LTO4 HH SAS
6171S5R	IBM TS2900 Tape Autoloader w/LTO5 HH SAS
6171S6R	IBM TS2900 Tape Autoloader w/LTO6 HH SAS
61732UL	IBM TS3100 Tape Library Model L2U
61734UL	IBM TS3200 Tape Library Model L4U
Fibre Channel backup drives for TS3100 and TS3200 Tape Libraries	
00NA101	6173 LTO Ultrium 4 Fibre Channel Drive Sled
00NA103	6173 LTO Ultrium 4 Half High Fibre Drive Sled
00NA107	6173 LTO Ultrium 5 Fibre Channel Drive
00NA113	6173 LTO Ultrium 5 Half High Fibre Drive Sled
00NA115	6173 LTO Ultrium 6 Fibre Channel Drive
00NA119	6173 LTO Ultrium 6 Half High Fibre Drive Sled
SAS backup drives for TS3100 and TS3200 Tape Libraries	
00NA121	6173 LTO Ultrium 4 SAS Drive Sled
00NA105	6173 LTO Ultrium 4 Half High SAS DriveV2 Sled
00NA109	6173 LTO Ultrium 5 SAS Drive Sled
00NA111	6173 LTO Ultrium 5 Half High SAS Drive Sled
00NA117	6173 LTO Ultrium 6 Half High SAS Drive Sled

For more information, see the list of Product Guides in the Backup units category:

<http://lenovopress.com/systemx/tape>

Top-of-rack Ethernet switches

The following table lists the top-of-rack Ethernet switches that are offered by Lenovo that can be used in x3550 M4 solutions.

Table 29. Top-of-rack switches

Part number	Description
1 Gb Ethernet top-of-rack switches	
7159BAX	Lenovo RackSwitch G7028 (Rear to Front)
7159CAX	Lenovo RackSwitch G7052 (Rear to Front)
7159G52	Lenovo RackSwitch G8052 (Rear to Front)
10 Gb Ethernet top-of-rack switches	
7159BR6	Lenovo RackSwitch G8124E (Rear to Front)
7159G64	Lenovo RackSwitch G8264 (Rear to Front)
7159DRX	Lenovo RackSwitch G8264CS (Rear to Front)
7159CRW	Lenovo RackSwitch G8272 (Rear to Front)
7159GR6	Lenovo RackSwitch G8296 (Rear to Front)
40 Gb Ethernet top-of-rack switches	
7159BRX	Lenovo RackSwitch G8332 (Rear to Front)

For more information, see the list of Product Guides in the Top-of-rack switches category:

<http://lenovopress.com/systemx/tor>

Uninterruptible power supply units

The following table lists the uninterruptible power supply (UPS) units that are offered by Lenovo that can be used in x3550 M4 solutions.

Table 30. Uninterruptible power supply units

Part number	Description
55941AX	RT1.5kVA 2U Rack or Tower UPS (100-125VAC)
55941KX	RT1.5kVA 2U Rack or Tower UPS (200-240VAC)
55942AX	RT2.2kVA 2U Rack or Tower UPS (100-125VAC)
55942KX	RT2.2kVA 2U Rack or Tower UPS (200-240VAC)
55943AX	RT3kVA 2U Rack or Tower UPS (100-125VAC)
55943KX	RT3kVA 2U Rack or Tower UPS (200-240VAC)
55945KX	RT5kVA 3U Rack or Tower UPS (200-240VAC)
55946KX	RT6kVA 3U Rack or Tower UPS (200-240VAC)
55948KX	RT8kVA 6U Rack or Tower UPS (200-240VAC)
55949KX	RT11kVA 6U Rack or Tower UPS (200-240VAC)
55948PX	RT8kVA 6U 3:1 Phase Rack or Tower UPS (380-415VAC)
55949PX	RT11kVA 6U 3:1 Phase Rack or Tower UPS (380-415VAC)

For more information, see the list of Product Guides in the Power infrastructure category:

<http://lenovopress.com/systemx/power>

Power distribution units

The following table lists the power distribution units (PDUs) that are offered by Lenovo that can be used in x3550 M4 solutions.

Table 31. Power distribution units

Part number	Description
0U Basic PDUs	
46M4122	0U 24 C13 16A 3 Phase PDU with IEC 309 P+N+Gnd line cord
46M4125	0U 24 C13 30A 3 Phase PDU with NEMA L21-30P line cord
46M4128	0U 24 C13 30A PDU with NEMA L6-30P line cord
46M4131	0U 24 C13 32A PDU with IEC 309 P+N+Gnd line cord
46M4143	0U 12 C19/12 C13 32A 3 Phase PDU with IEC 309 3P+N+Gnd line cord
46M4140	0U 12 C19/12 C13 60A 3 Phase PDU with CS8365L 3P+Gnd line cord
Switched and Monitored PDUs	
46M4002	1U 9 C19/3 C13 Switched and Monitored DPI PDU (without line cord)
46M4003	1U 9 C19/3 C13 Switched and Monitored 60A 3 Phase PDU with IEC 309 3P+Gnd line cord
46M4004	1U 12 C13 Switched and Monitored DPI PDU (without line cord)
46M4005	1U 12 C13 Switched and Monitored 60A 3 Phase PDU with IEC 309 3P+Gnd line cord
46M4167	1U 9 C19/3 C13 Switched and Monitored 30A 3 Phase PDU with NEMA L21-30P line cord
46M4116	0U 24 C13 Switched and Monitored 30A PDU with NEMA L6-30P line cord
46M4119	0U 24 C13 Switched and Monitored 32A PDU with IEC 309 P+N+Gnd line cord
46M4137	0U 12 C19/12 C13 Switched and Monitored 32A 3 Phase PDU with IEC 309 3P+N+Gnd cord
46M4134	0U 12 C19/12 C13 Switched and Monitored 50A 3 Phase PDU with CS8365L 3P+Gnd cord
Ultra Density Enterprise PDUs (9x IEC 320 C13 + 3x IEC 320 C19 outlets)	
71762NX	Ultra Density Enterprise C19/C13 PDU Module (without line cord)
71762MX	Ultra Density Enterprise C19/C13 PDU+ Module (without line cord)
71763NU	Ultra Density Enterprise C19/C13 PDU 60A/208V/3ph with IEC 309 3P+Gnd line cord
71763MU	Ultra Density Enterprise C19/C13 PDU+ 60A/208V/3ph with IEC 309 3P+Gnd line cord
C13 Enterprise PDUs (12x IEC 320 C13 outlets)	
39M2816	DPI C13 Enterprise PDU+ (without line cord)
39Y8941	DPI Single Phase C13 Enterprise PDU (without line cord)
C19 Enterprise PDUs (6x IEC 320 C19 outlets)	
39Y8948	DPI Single Phase C19 Enterprise PDU (without line cord)
39Y8923	DPI 60A 3 Phase C19 Enterprise PDU with IEC 309 3P+G (208 V) fixed line cord
Front-end PDUs (3x IEC 320 C19 outlets)	
39Y8938	DPI 30amp/125V Front-end PDU with NEMA L5-30P line cord
39Y8939	DPI 30amp/250V Front-end PDU with NEMA L6-30P line cord
39Y8934	DPI 32amp/250V Front-end PDU with IEC 309 2P+Gnd line cord
39Y8940	DPI 60amp/250V Front-end PDU with IEC 309 2P+Gnd line cord
39Y8935	DPI 63amp/250V Front-end PDU with IEC 309 2P+Gnd line cord
Universal PDUs (7x IEC 320 C13 outlets)	
39Y8951	DPI Universal Rack PDU with US LV and HV line cords
39Y8952	DPI Universal Rack PDU with CEE7-VII Europe line cord
39Y8953	DPI Universal Rack PDU with Denmark line cord

Part number	Description
39Y8954	DPI Universal Rack PDU with Israel line cord
39Y8955	DPI Universal Rack PDU with Italy line cord
39Y8956	DPI Universal Rack PDU with South Africa line cord
39Y8957	DPI Universal Rack PDU with UK line cord
39Y8958	DPI Universal Rack PDU with AS/NZ line cord
39Y8959	DPI Universal Rack PDU with China line cord
39Y8962	DPI Universal Rack PDU (Argentina)
39Y8960	DPI Universal Rack PDU (Brazil)
39Y8961	DPI Universal Rack PDU (India)
NEMA PDUs (6x NEMA 5-15R outlets)	
39Y8905	DPI 100-127V PDU with Fixed NEMA L5-15P line cord
Line cords for PDUs that ship without a line cord	
40K9611	DPI 32a Line Cord (IEC 309 3P+N+G)
40K9612	DPI 32a Line Cord (IEC 309 P+N+G)
40K9613	DPI 63a Cord (IEC 309 P+N+G)
40K9614	DPI 30a Line Cord (NEMA L6-30P)
40K9615	DPI 60a Cord (IEC 309 2P+G)
40K9617	DPI Australian/NZ 3112 Line Cord
40K9618	DPI Korean 8305 Line Cord

For more information, see the list of Product Guides in the Power infrastructure category:
<http://lenovopress.com/systemx/power>

Rack cabinets

The following table lists the rack cabinets that are offered by Lenovo that can be used in x3550 M4 solutions.

Table 32. Rack cabinets

Part number	Description
201886X	11U Rack Office Enablement Kit
93072RX	25U S2 Standard Rack
93072PX	25U Static S2 Standard Rack
93074RX	42U S2 Standard Rack
93634PX	42U 1100mm Enterprise V2 Dynamic Rack
93634EX	42U 1100mm Enterprise V2 Dynamic Expansion Rack
93604PX	42U 1200mm Deep Dynamic Rack
93614PX	42U 1200mm Deep Static Rack
93084PX	42U Enterprise Rack
93084EX	42U Enterprise Expansion Rack

For more information, see the list of Product Guides in the Rack cabinets and options category:
<http://lenovopress.com/systemx/rack>

Rack options

The server supports the rack console switches and monitor kits listed in the following table.

Table 37. Rack options

Part number	Feature code	Description
Monitor kits and keyboard trays		
17238BX	1723HC1 fc A3EK	1U 18.5" Standard Console
17238EX	1723HC1 fc A3EL	1U 18.5" Enhanced Media Console
172317X	1723HC1 fc 0051	1U 17in Flat Panel Console Kit
172319X	1723HC1 fc 0052	1U 19in Flat Panel Console Kit
Console switches		
3858D3X	3858HC1 fc A4X1	Avocent Universal Management Gateway 6000 for IBM
1754D2X	1754HC2 fc 6695	Global 4x2x32 Console Manager (GCM32)
1754D1X	1754HC1 fc 6694	Global 2x2x16 Console Manager (GCM16)
1754A2X	1754HC4 fc 0726	Local 2x16 Console Manager (LCM16)
1754A1X	1754HC3 fc 0725	Local 1x8 Console Manager (LCM8)
Console cables		
00AK142	A4X4	UM KVM Module VGA+SD Dual RJ45
43V6147	3757	Single Cable USB Conversion Option (UCO)
39M2895	3756	USB Conversion Option (4 Pack UCO)
39M2897	3754	Long KVM Conversion Option (4 Pack Long KCO)
46M5383	5341	Virtual Media Conversion Option Gen2 (VCO2)
46M5382	5340	Serial Conversion Option (SCO)

For more information, see the list of Product Guides in the Rack cabinets and options category:

<http://lenovopress.com/systemx/rack>

Lenovo Financial Services

Lenovo Financial Services reinforces Lenovo's commitment to deliver pioneering products and services that are recognized for their quality, excellence, and trustworthiness. Lenovo Financial Services offers financing solutions and services that complement your technology solution anywhere in the world.

We are dedicated to delivering a positive finance experience for customers like you who want to maximize your purchase power by obtaining the technology you need today, protect against technology obsolescence, and preserve your capital for other uses.

We work with businesses, non-profit organizations, governments and educational institutions to finance their entire technology solution. We focus on making it easy to do business with us. Our highly experienced team of finance professionals operates in a work culture that emphasizes the importance of providing outstanding customer service. Our systems, processes and flexible policies support our goal of providing customers with a positive experience.

We finance your entire solution. Unlike others, we allow you to bundle everything you need from hardware and software to service contracts, installation costs, training fees, and sales tax. If you decide weeks or months later to add to your solution, we can consolidate everything into a single invoice.

Our Premier Client services provide large accounts with special handling services to ensure these complex transactions are serviced properly. As a premier client, you have a dedicated finance specialist who manages your account through its life, from first invoice through asset return or purchase. This specialist develops an in-depth understanding of your invoice and payment requirements. For you, this dedication provides a high-quality, easy, and positive financing experience.

For your region specific offers please ask your Lenovo sales representative or your technology provider about the use of Lenovo Financial Services. For more information, see the following Lenovo website:

<http://www.lenovofs.com>

Related publications and links

For more information see these resources:

- Lenovo Servers product page
<http://www.lenovo.com/systems/servers>
- System x3550 M4 documentation
http://publib.boulder.ibm.com/infocenter/systemx/documentation/topic/com.lenovo.sysx.7914.doc/c_product_page.html
- ServerProven hardware compatibility page for the x3550 M4 (E5-2600)
<http://www.lenovo.com/us/en/serverproven/xseries/7914.shtml>
- US Announcement Letter - August 21, 2012
- <http://ibm.com/common/ssi/cgi-bin/ssialias?infotype=dd&subtype=ca&&htmlfid=897/ENUS112-140>
- US Announcement Letter - March 6, 2012
<http://ibm.com/common/ssi/cgi-bin/ssialias?infotype=dd&subtype=ca&&htmlfid=897/ENUS112-043>
- Lenovo Press Product Guides for System x servers and options
<http://lenovopress.com>
- Configuration and Option Guide
<http://www.ibm.com/systems/xbc/cog/>
- xREF - System x Reference Sheets
<http://lenovopress.com/xref>
- Support Portal - System x3550 M4
http://www.ibm.com/support/entry/portal/product/lenovo_x86_servers/lenovo_system_x3550_m4
- System Storage Interoperation Center
<http://www.ibm.com/systems/support/storage/ssic>

Related product families

Product families related to this document are the following:

- [2-Socket Rack Servers](#)

Notices

Lenovo may not offer the products, services, or features discussed in this document in all countries. Consult your local Lenovo representative for information on the products and services currently available in your area. Any reference to a Lenovo product, program, or service is not intended to state or imply that only that Lenovo product, program, or service may be used. Any functionally equivalent product, program, or service that does not infringe any Lenovo intellectual property right may be used instead. However, it is the user's responsibility to evaluate and verify the operation of any other product, program, or service. Lenovo may have patents or pending patent applications covering subject matter described in this document. The furnishing of this document does not give you any license to these patents. You can send license inquiries, in writing, to:

Lenovo (United States), Inc.
8001 Development Drive
Morrisville, NC 27560
U.S.A.
Attention: Lenovo Director of Licensing

LENOVO PROVIDES THIS PUBLICATION "AS IS" WITHOUT WARRANTY OF ANY KIND, EITHER EXPRESS OR IMPLIED, INCLUDING, BUT NOT LIMITED TO, THE IMPLIED WARRANTIES OF NON-INFRINGEMENT, MERCHANTABILITY OR FITNESS FOR A PARTICULAR PURPOSE. Some jurisdictions do not allow disclaimer of express or implied warranties in certain transactions, therefore, this statement may not apply to you.

This information could include technical inaccuracies or typographical errors. Changes are periodically made to the information herein; these changes will be incorporated in new editions of the publication. Lenovo may make improvements and/or changes in the product(s) and/or the program(s) described in this publication at any time without notice.

The products described in this document are not intended for use in implantation or other life support applications where malfunction may result in injury or death to persons. The information contained in this document does not affect or change Lenovo product specifications or warranties. Nothing in this document shall operate as an express or implied license or indemnity under the intellectual property rights of Lenovo or third parties. All information contained in this document was obtained in specific environments and is presented as an illustration. The result obtained in other operating environments may vary. Lenovo may use or distribute any of the information you supply in any way it believes appropriate without incurring any obligation to you.

Any references in this publication to non-Lenovo Web sites are provided for convenience only and do not in any manner serve as an endorsement of those Web sites. The materials at those Web sites are not part of the materials for this Lenovo product, and use of those Web sites is at your own risk. Any performance data contained herein was determined in a controlled environment. Therefore, the result obtained in other operating environments may vary significantly. Some measurements may have been made on development-level systems and there is no guarantee that these measurements will be the same on generally available systems. Furthermore, some measurements may have been estimated through extrapolation. Actual results may vary. Users of this document should verify the applicable data for their specific environment.

© Copyright Lenovo 2024. All rights reserved.

This document, LP0038, was created or updated on December 10, 2015.

Send us your comments in one of the following ways:

- Use the online Contact us review form found at:
<https://lenovopress.lenovo.com/LP0038>
- Send your comments in an e-mail to:
comments@lenovopress.com

This document is available online at <https://lenovopress.lenovo.com/LP0038>.

Trademarks

Lenovo and the Lenovo logo are trademarks or registered trademarks of Lenovo in the United States, other countries, or both. A current list of Lenovo trademarks is available on the Web at <https://www.lenovo.com/us/en/legal/copytrade/>.

The following terms are trademarks of Lenovo in the United States, other countries, or both:

Lenovo®

ServerProven®

System x®

The following terms are trademarks of other companies:

Intel® and Xeon® are trademarks of Intel Corporation or its subsidiaries.

Linux® is the trademark of Linus Torvalds in the U.S. and other countries.

Microsoft®, Windows Server®, and Windows® are trademarks of Microsoft Corporation in the United States, other countries, or both.

Other company, product, or service names may be trademarks or service marks of others.